

CONTENTS

10.0 RIGGING HARDWARE..... 3

    10.1 SCOPE..... 3

    10.2 SHACKLES AND RINGS..... 3

        10.2.1 General..... 3

        10.2.2 Marking and Tagging..... 4

        10.2.3 Inspection..... 4

        10.2.4 Operation..... 5

        10.2.5 Proof Load Testing and Tagging..... 5

    10.3 WIRE ROPE CLAMPS..... 7

        10.3.1 General..... 7

        10.3.2 Inspection..... 11

    10.4 EYEBOLTS, MANUFACTURER-INSTALLED LIFT POINTS, AND SWIVEL HOIST RINGS..... 11

        10.4.1 Manufacturer-Installed Eyebolts vs. Eyebolts Used as Rigging Hardware..... 11

        10.4.2 Manufacturer-Installed Lift Points..... 11

        10.4.3 Eyebolts—Rigging Hardware..... 11

        10.4.4 Inspection—Eyebolts..... 12

        10.4.5 Operation—Eyebolts..... 14

        10.4.6 Inspection—Swivel Hoist Rings..... 16

        10.4.7 Qualification—Eyebolts and Swivel Hoist Rings..... 17

    10.5 TURNBUCKLES..... 18

    10.5 TURNBUCKLES..... 19

        10.5.1 General..... 19

        10.5.2 Inspection..... 19

        10.5.3 Testing of Turnbuckles..... 20

        10.5.4 Qualification..... 20

    10.6 RIGGING HOOKS..... 20

        10.6.1 General..... 20

        10.6.2 Inspection..... 22

**LIST OF FIGURES**

Figure 10-1. Typical Shackles. .... 4  
Figure 10-2. Replacing Shackle Pins. .... 6  
Figure 10-3. Eccentric Shackle Loads. .... 6  
Figure 10-4. Improper use of a Screw Pin Shackle. .... 7  
Figure 10-5. Type I, II, and III Wire Rope Clamps. .... 8  
Figure 10-6. Wire Rope Clips, Type I.\*\* ..... 9  
Figure 10-7. Wire Rope Clamp Details, Type III.\*\* ..... 10  
Figure 10-8. Use of Shoulder-Type Eyebolts. .... 15  
Figure 10-9. Orientation of Eyebolts. .... 15  
Figure 10-10. Guidelines for Attaching and Using Swivel Hoist Rings. .... 18  
Figure 10-11. Turnbuckle Types, Inspection Areas, and Safe Working Load..... 21  
Figure 10-12. Miscellaneous Hooks. .... 23

**LIST OF TABLES**

Table 10-1. Safe Working Load for Carbon Steel Shouldered Eyebolts (ANSI/ASME B18.15). ..... 13

## 10.0 RIGGING HARDWARE

### 10.1 SCOPE

This section provides requirements for qualification and use of rigging hardware for lifting service and includes shackles, rings, wire rope clamps (clips), eyebolts, turnbuckles, and rigging hooks. The use of other commercially made rigging hardware designed for overhead lifting that is not included in this section (e.g., patented products) requires management approval.

### 10.2 SHACKLES AND RINGS

#### 10.2.1 General

Requirements and guidelines for shackles and rings are as follows.

1. Shackle specifications are defined by the following documents, depending on the shackle size:
  - a. For shackles 3/16 to 2 3/4 inches, the specifications are derived from Federal Specification RR-C-271, "Chains and Attachments, Welded and Weldless."
  - b. For shackles 1 1/2 to 4 inches, the specifications are derived from MIL-S-24214, "Shackles, Steel, General Purpose and High Strength."
  - c. For shackles 4 1/2 to 8 1/2 inches, ASTM A148M, "Standard Specification for Steel Castings, High Strength, For Structural Purposes," should be used.

**NOTE:** For the overlaps in size, with RR-C-271 and MIL-S-24214, either specification may be used; however, RR-C-271 is most commonly used. Specification RR-C-271, Revision D, was issued in September 1990. Catalogs and manufacturers' literature will list the federal specification number as "RR-C-271(rev.)."

2. Shackles are manufactured in two configurations for use in rigging: anchor shackle and chain shackle. Both are available with screw pins, round pins, or safety bolts (Fig. 10-1).
3. Shackles are sized by the diameter of steel in the bow section rather than the pin size.
4. Design Factors: Shackles manufactured in accordance with RR-C-271 and MIL-S-24214 have a minimum design factor of 5. Shackles manufactured to the requirements of ASTM A148M have a minimum design factor of 4. Rings manufactured to the requirements of RR-C-271 have a minimum design factor of 6.
5. Rings should be forged steel and weldless. Welded rings are not recommended but may be used if designed by a qualified engineer and subjected to weld nondestructive testing (NDT).

Figure 10-1. Typical Shackles.

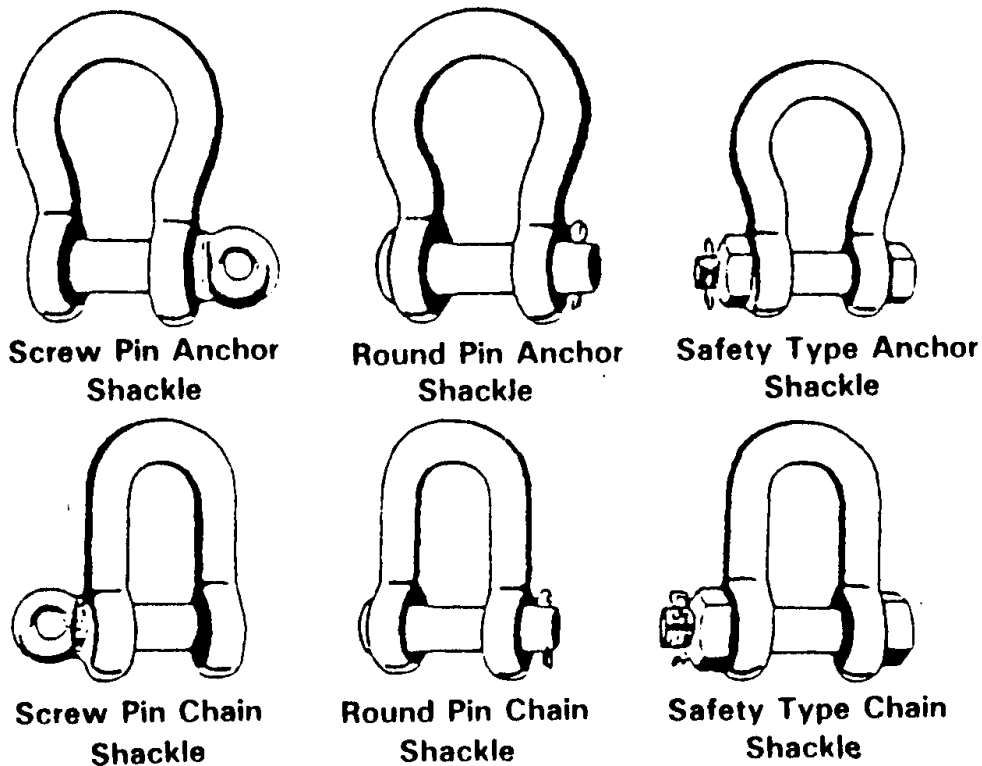

### 10.2.2 Marking and Tagging

1. Each shackle body shall be permanently and legibly marked by the manufacturer. Marking will be raised or stamped letters on the side of the shackle bow with an identifying manufacturer's name or trademark, shackle size, and safe working load (SWL).
2. Shackle pins shall be unmarked.
3. Shackles and rings that have been proof tested for critical service shall have a tag or other marking to indicate clearly to the user that proof testing has been done.

### 10.2.3 Inspection

Inspection criteria for shackles and rings are listed below.

1. Before each use, shackles shall be inspected to the following criteria.
  - a. Shackle pins shall fit freely without binding. (Seated screw pin shackles shall be disassembled by hand after the first-half turn.)
  - b. The pin shall show no sign of deformation.
  - c. The shackle shall have no defect that will interfere with serviceability.

2. Shackles and rings for critical-lift service shall have an initial proof load test of two times the SWL (minimum). Before making a critical lift, ensure that the shackle or ring has been proof tested.
3. Before each use, rings shall be visually inspected for damage, corrosion, wear, cracks, twists, and opening.

#### 10.2.4 Operation

Operating practices and guidelines for the use of shackles are as follows.

1. The shackle pin shall never be replaced with a bolt; only a properly fitted pin shall be used. Bolts are not intended to take the load that is normally applied to the pin (Fig. 10-2).
2. Shackles shall not be used if the pin cannot be completely seated.
3. Shackles shall never be pulled at an angle because the capacity will be tremendously reduced. Centralize whatever is being hoisted on the pin by suitable washers or spacers (Fig. 10-3).
4. Screw pin shackles shall not be used if the pin can roll under load and unscrew (Fig. 10-4).

#### 10.2.5 Proof Load Testing and Tagging

A proof load test (minimum, two times SWL) is required for shackles and rings used in critical-lift service. A validated proof load test, conducted by the manufacturer or the Hanford Site contractor, meets this requirement.

**NOTE:** A critical-lift procedure may call for additional load testing or proof load testing of rigging and rigging hardware.

Figure 10-2. Replacing Shackle Pins.

**Never Replace a Shackle Pin with a Bolt**

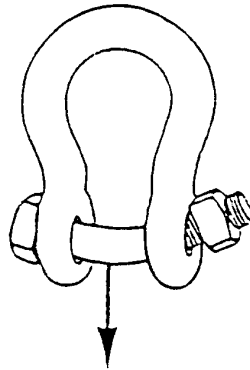

**The Load will Bend the Bolt**

38807139.17

Figure 10-3. Eccentric Shackle Loads.

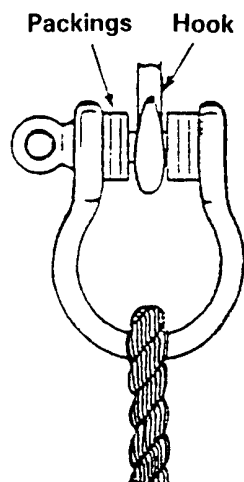

**Good Practice**  
Pack the Pin  
with Washers  
to Centralize  
the Shackle

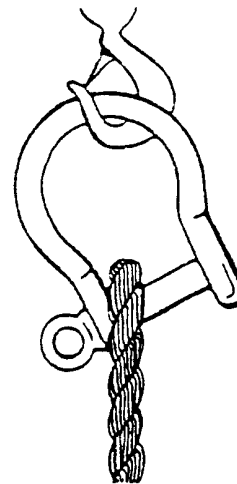

**Poor Practice**  
Never Allow Shackle  
to be Pulled at an  
Angle, the Legs  
will Open Up

38807139.23

Figure 10-4. Improper use of a Screw Pin Shackle.

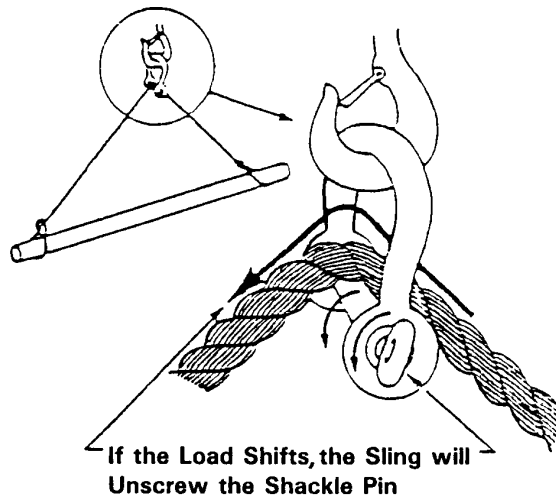

38805-185.27

## 10.3 WIRE ROPE CLAMPS

### 10.3.1 General

Requirements and guidelines for wire rope clamps are as follows.

1. Clamps (also called clips) shall meet or exceed the requirements of Federal Specification FF-C-450, "Clamps, Wire Rope."
2. Clamps shall be legibly and permanently marked with size and the manufacturer's identifying mark.
3. Clamps of the same size, type, and class, with the exception of Type IV, shall assemble readily with random selection of component parts (see Fig. 10-5). Type IV half clamps are fabricated in matching pairs and parts are not interchangeable. (See Fig. 10-5 for the four types of clamps. See Fig. 10-6 for installation details for Type I wire rope clamps. See Fig. 10-7 for installation details for Type III wire rope clamps.)
4. For application information see para 9.2.3, "Wire Rope Slings," and Fig. 9-8.

Figure 10-5. Type I, II, and III Wire Rope Clamps.

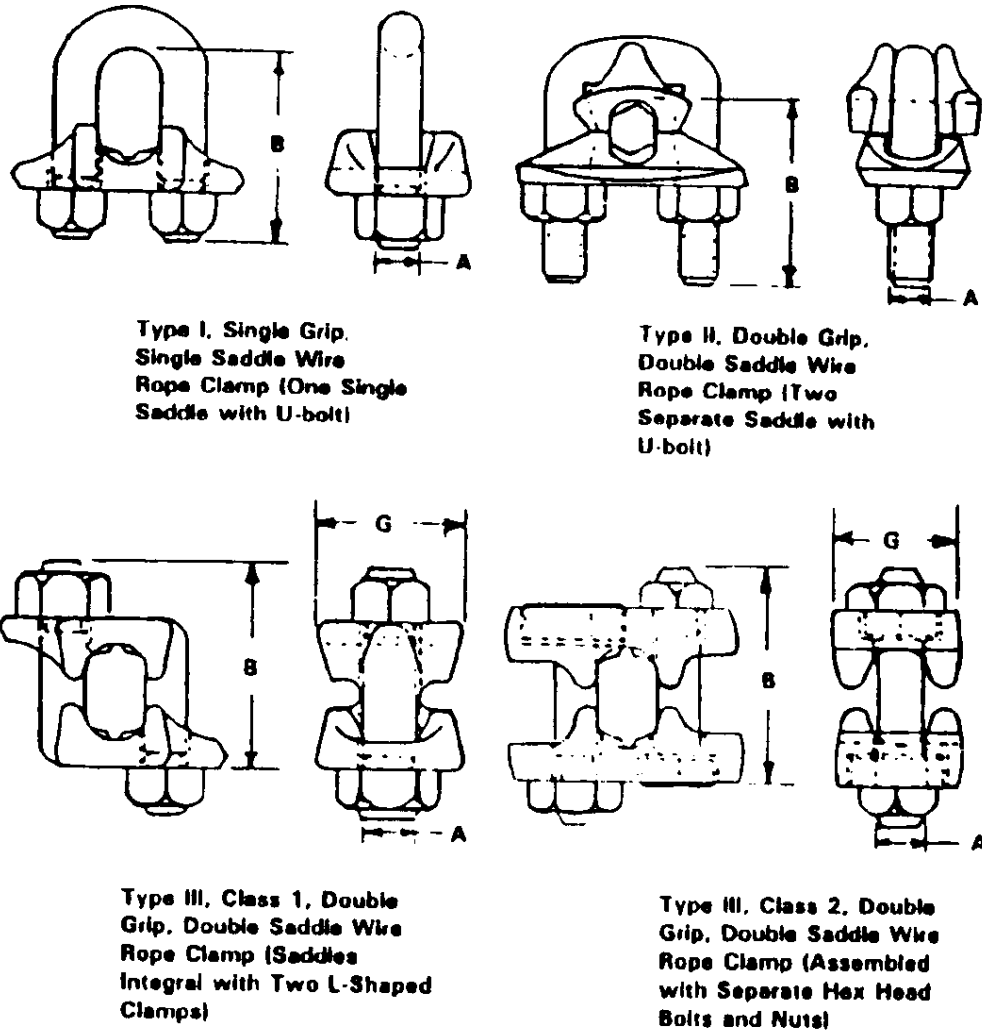
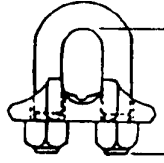



Figure 10-6. Wire Rope Clips, Type I.\*\*



Clip size (inch) and rope size	Minimum number of clips	Amount of rope to turn back in inches	*Torque in ft lbs.
1/8	2	3 1/4	4.5
3/16	2	3 3/4	7.5
1/4	2	4 3/4	15
5/16	2	5 1/4	30
3/8	2	6 1/2	45
7/16	2	7	65
1/2	3	11 1/2	65
9/16	3	12	95
5/8	3	12	95
3/4	4	18	130
7/8	4	19	225
1	5	26	225
1 1/8	6	34	225
1 1/4	7	44	360
1 3/8	7	44	360
1 1/2	8	54	360
1 5/8	8	58	430
1 3/4	8	61	590
2	8	71	750
2 1/4	8	73	750
2 1/2	9	84	750
2 3/4	10	100	750
3	10	106	1,200
3 1/2	12	149	1,200

- NOTES: 1. If a pulley (sheave) is used for turning back the wire rope, add one additional clip.
2. If a greater number of clips are used than shown in the table, the amount of turnback should be increased proportionally.
3. The number of clips shown is based upon using RRL of RLL wire rope 6 by 19 or 6 by 37 Class FC or IWRC; IPS or XIP. If Seale construction or similar large outer wire type construction in the 6 by 19 Class is to be used for sizes 1 inch and larger, add one additional clip.
4. The number of clips shown also applies to rotation-resistant RRL wire rope, 8 by 19 Class, IPS, XIP, sizes 1 1/2 inch and smaller; and to rotation-resistant RRL wire rope, 19 by 7 Class, IPS, XIP, sizes 1 3/4 inch smaller.
5. Efficiency ratings for wire rope and terminations are based on the catalog breaking strength of wire rope. The efficiency rating of a properly prepared loop or thimble - eye termination for clip sizes 1/8 in. through 7/8 in. is 80 percent, and for sizes 1 in. through 3 1/2 in. is 90 percent.

\*The tightening torque values shown are based on the threads being clean, dry, and free of lubrication.

\*\*Figure derived from The Crosby General Catalog, courtesy of The Crosby Group, Inc., Tulsa, OK.

Figure 10-7. Wire Rope Clamp Details, Type III.\*\*

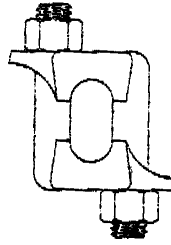

Clip size (inch) and rope size	Minimum number of clips	Amount of rope to turn back in inches	*Torque in ft lbs
3/16	2	4	30
1/4	2	4	30
5/16	2	5	30
3/8	2	5 1/4	45
7/16	2	6 1/2	65
1/2	3	11	65
9/16	3	12 3/4	130
5/8	3	13 1/2	130
3/4	3	16	225
7/8	4	26	225
1	5	37	225
1 1/8	5	41	360
1 1/4	6	55	360
1 3/8	6	62	500
1 1/2	7	78	500

- NOTES: 1. If a pulley (sheave) is used for turning back the wire rope, add one additional clip.
2. If a greater number of clips are used than shown in the table, the amount of turnback should be increased proportionally.
3. The number of clips shown (see Table 1) is based on using RRL of RLL wire rope 6 by 19 or 6 by 37 Class FC or IWRC; IPS or XIP. If Seale construction or similar large outer wire type construction in the 6 by 19 Class is to be used for sizes 1 inch and larger, add one additional clip.
4. The number of clips shown also applies to rotation resistant RRL wire rope, 8 by 19 Class, IPS, XIP, sizes 1 1/2 inch and smaller; and to rotation-resistant RRL wire rope, 19 by 7 Class, IPS, XIP, sizes 1 1/2 inch smaller.
5. Efficiency ratings for wire rope and terminations are based on the catalog breaking strength of wire rope. The efficiency rating of a properly prepared loop or thimble-eye termination for clip sizes 1/8 in. through 7/8 in. is 80 percent, and for sizes 1 in. through 3 1/2 in. is 90 percent.
- \*The tightening torque values shown are based on the threads being clean, dry, and free of lubrication.

\*\*Figure derived from The Crosby General Catalog, courtesy of The Crosby Group, Inc., Tulsa, Oklahoma.

### 10.3.2 Inspection

Inspection criteria for wire rope clamps follow:

1. Before use, clamps shall be visually inspected for damage, corrosion, wear, and cracks.
2. Verify that the clamp components are marked in accordance with para 10.3.1, "General," item 2.
3. Ensure that the assembled clamp contains the same size, type, and class parts.

## 10.4 EYEBOLTS, MANUFACTURER-INSTALLED LIFT POINTS, AND SWIVEL HOIST RINGS

### 10.4.1 Manufacturer-Installed Eyebolts vs. Eyebolts Used as Rigging Hardware

This section specifies requirements for eyebolts that are used as rigging hardware during normal hoisting and rigging (H&R) activities. Eyebolts designed for and permanently installed by the manufacturer on existing engineered equipment are considered part of the engineered equipment. They may not meet all requirements specified for rigging hardware. Eyebolts permanently installed on engineered equipment are acceptable for their intended use as long as they pass visual inspection before use.

It is important to know how the manufacturer of engineered equipment intends permanently installed eyebolts to be used. In some cases the intended use is obvious to an experienced craftsman and in other cases engineering review of vendor information may be necessary. In either case, when special eyebolt use instructions are provided by the manufacturer or vendor, such instructions shall be followed.

**CAUTION:** Eyebolts installed by the manufacturer to lift only parts of the engineered equipment are not suitable for lifting the completely assembled piece of equipment. When questions arise regarding the use of manufacturer-installed eyebolts, the equipment custodian or cognizant engineer shall be consulted.

### 10.4.2 Manufacturer-Installed Lift Points

All manufacturer-installed lift points shall be inspected and evaluated by a qualified person before use for cracks, deformation, excessive wear, or damage. When questions arise regarding the use of manufacturer-installed lift points, the equipment custodian or cognizant engineer shall be consulted.

### 10.4.3 Eyebolts—Rigging Hardware

1. Only shouldered eyebolts (Type 2)<sup>1</sup> shall be used for rigging hardware, except when prohibited by the configuration of the item to which the eyebolt is attached. Where nonshouldered eyebolts (Type 1)<sup>2</sup> are required, they shall be used only in vertical pulls<sup>3</sup> or in rigging systems that are designed, analyzed, and approved by a qualified person.

<sup>1</sup>Type 2--Shouldered Eyebolt.

<sup>2</sup>Type 1--Straight Shank Eyebolt (nonshouldered).

2. Eyebolt marking:
  - a. **Carbon Steel Eyebolts.** Each eyebolt shall have the manufacturer's name or identification mark forged in raised characters on the surface of the eyebolt.
  - b. **Alloy Steel Eyebolts.** Each eyebolt shall have the symbol "A" (denoting alloy steel) and the manufacturer's name or identification mark forged in raised characters on the surface of the eyebolt.
3. Eyebolts shall have a minimum design factor of 5, based on ultimate strength. Table 10-1 reflects the safe working load (SWL) as listed in ANSI/ASME B18.15, "Forged Eyebolts." Eyebolts from selected manufacturers may have a higher SWL. For higher SWLs a design factor of no less than 5 shall be verified before use.
4. Carbon steel eyebolts shall be made of forged carbon steel. Alloy steel eyebolts are forged, quenched, and tempered with improved toughness properties, intended primarily for low-temperature applications.
5. Nuts, washers, and drilled plates shall not be used or assembled to make shouldered eyebolts. Wire type and/or welded eyebolts shall not be used in lifting operations.
6. Shoulders shall seat uniformly and snugly against the surface on which they bear.<sup>4</sup>

**CAUTION:** Size 7/8-inch eyebolts should not be used because a 7/8-9 UNC thread may be threaded into a 1-8 UNC tapped hole but will fail when loaded.

#### 10.4.4 Inspection—Eyebolts

Inspection criteria for eyebolts are as follows:

1. Careful visual inspection of each eyebolt immediately before use is mandatory. Eyebolts that are cracked, bent, or have damaged threads shall be discarded.
2. The shank of the eyebolt shall not be undercut and shall be smoothly radiused into the plane of the shoulder.

---

<sup>3</sup>For vertical loading, eyebolts without shoulders have the same load-carrying ability as shouldered eyebolts; however, nonshouldered eyebolts are subject to bending, thus severely reducing their safe working load.

<sup>4</sup>If the shoulder does not bear firmly against the mating part, the capacity of a shouldered eyebolt is reduced to that of a nonshouldered eyebolt.

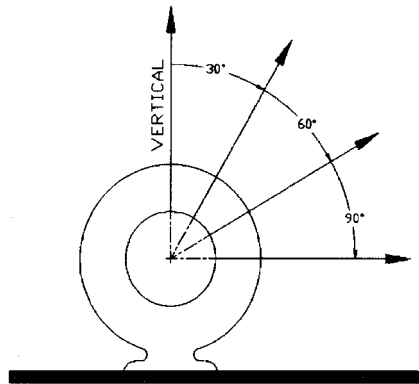

Table 10-1. Safe Working Load for Carbon Steel Shouldered Eyebolts (ANSI/ASME B18.15).

Nominal size (in.)	Inside diameter of eye (in.)	Safe Working Load per Shouldered Eyebolt (lb)			
		Vertical	30° from vertical	60° from vertical	90° from vertical
1/4	0.69	400	75	NR*	NR*
3/8	0.94	1,000	400	220	180
1/2	1.12	1,840	850	520	440
5/8	1.31	2,940	1,410	890	740
3/4	1.44	4,340	2,230	1,310	1,140
1	1.69	7,880	3,850	2,630	2,320
1 1/4	2.12	12,600	6,200	4,125	3,690
1 1/2	2.44	18,260	9,010	6,040	5,460
2	3.06	32,500	15,970	10,910	9,740

\*NR means not recommended.

- Limiting Conditions:
- To attain the rated capacity for threaded hole applications, minimum thread shank length of engagement depends on parent material and must be as follows:  
Steel: 1 thread diameter  
Cast iron, brass, bronze: 1.5 times the thread diameter  
Aluminum, magnesium, zinc, plastic: 2 times the thread diameter
  - To attain the rated capacity for untapped through-hole applications, use shouldered eyebolts, steel washer, and a nut with required thread engagement.
  - Under vertical load, Type 1, straight shank (nonshouldered) eyebolts have the same safe working load as shouldered eyebolts. Angular loading is restricted, reference para 10.4.2, "Eyebolts-Rigging Hardware."
  - Capacities shown in this table are for carbon steel ASTM A-489 eyebolts at temperatures between 30 °F (-1 °C) and 275 °F (135 °C). Carbon steel is subject to failure from shock loading at temperatures below 30 °F and loses strength at temperatures above 275 °F.
  - Eyebolts from selected manufacturers may have higher SWL. Regardless of SWL, ensure that eyebolts have a design factor of 5.

#### 10.4.5 Operation—Eyebolts

Operating practices and guidelines for eyebolts are as follows.

1. The size of the hole shall be checked for the proper size of eyebolt before installation. The condition of the threads in the hole shall be checked to ensure that the eyebolt will secure and that the shoulder can be brought to a snug and uniformly engaged seat.
2. When installed, the shoulder of the eyebolt must be flush with the surface (Fig 10-8). When eyebolts cannot be properly seated and aligned with each other, a steel washer or spacer not to exceed one thread pitch may be required to put the plane of the eye in the direction of the load when the shoulder is seated (Fig. 10-9). Proper thread engagement must be maintained. Use a washer with approximately the same diameter as the eyebolt shoulder and the smallest inside diameter that will fit the eyebolt shank.
3. Angular loading of eyebolts should be avoided. Angular loading occurs in any lift in which the lifting force is applied at an angle to the centerline of the eyebolt shank.
4. When more than one eyebolt is used in conjunction with multiple-leg rigging, spreader bars, lifting yokes, or lifting beams should be used to eliminate angular loading. Where spreaders, yokes, or beams cannot be used, shouldered eyebolts may be used for angular lifting, providing the limiting conditions in Table 10-1 are considered.

Figure 10-8. Use of Shoulder-Type Eyebolts.

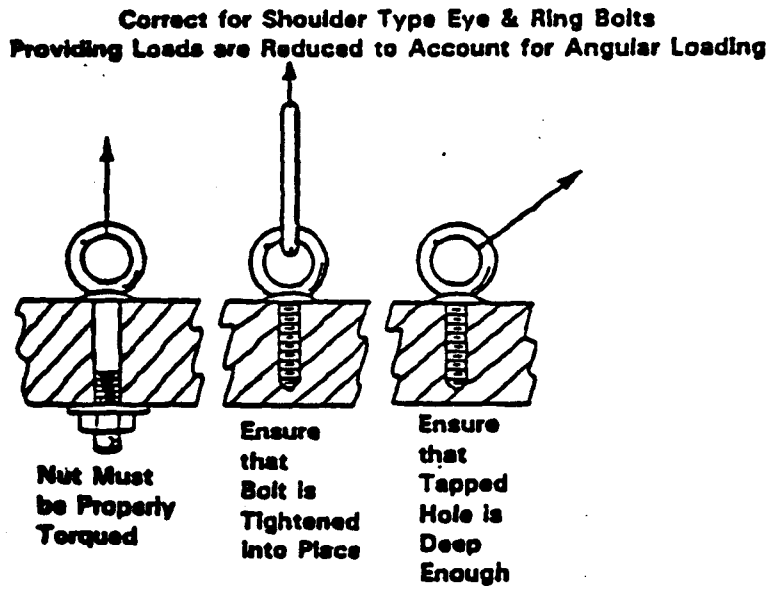
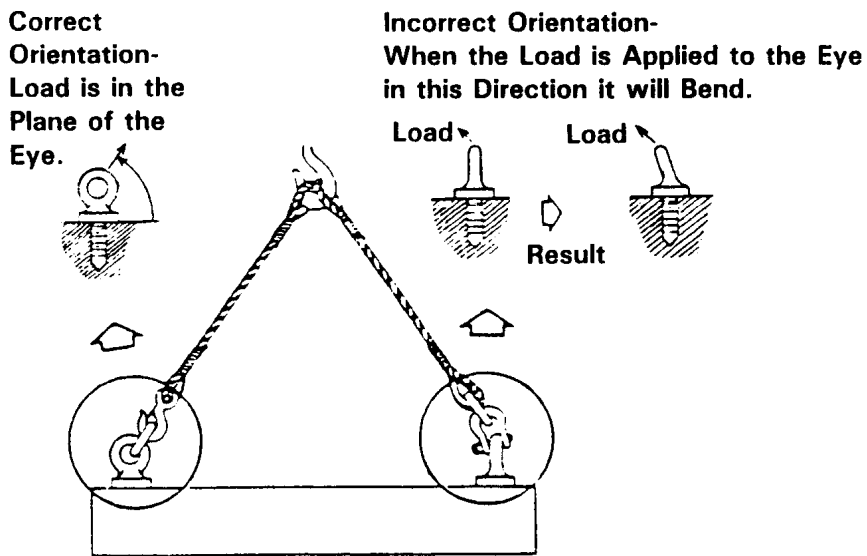

Figure 10-9. Orientation of Eyebolts.



38807139.1

5. To keep bending forces on the eyebolt to a minimum, the load shall always be applied in the plane of the eye, never in the other direction (Fig. 10-9).
6. If the hook will not go completely into the eyebolt, use a shackle to avoid loading the hook tip.

7. Slings shall not be reeved through an eyebolt or reeved through a pair of eyebolts. Only one leg should be attached to each eyebolt.

#### 10.4.6 Inspection—Swivel Hoist Rings

Inspection criteria for swivel hoist rings are as follows (See Fig. 10-10, Part B):

1. The minimum design factor shall be no less than 5 based on ultimate strength.
2. Ensure free movement of the bail. The range of movement shall be 360° swivel and 180° pivot.
3. The workpiece shall be tapped for a swivel hoist ring bolt with the axis perpendicular to the mounting surface. The work surface should be flat and smooth to provide flush seating for the bushing flange. The bolt should be tightened to the full torque loading. Unless otherwise recommended by the manufacturer, the torque tolerance is +25%, -0%.

**NOTE:** Loosening of a swivel hoist ring bolt may develop after prolonged service in a permanent installation. Periodically verify proper torque and retighten the mounting bolt as recommended by the manufacturer. In lieu of other direction from the manufacturer, check hoist swivel ring mounting bolts for proper torque before each lift.

4. Swivel hoist rings shall be provided with instructions from the manufacturer. They shall be marked to clearly identify the manufacturer, the safe working load, and the torque value. Swivel hoist rings are available in both UNC and metric thread sizes, so they shall also be marked to identify UNC or metric threads.
5. When a swivel hoist ring is installed with a retention nut, the nut must have no less than full thread engagement and shall be torqued in accordance with the manufacturer's recommendations. The nut must meet one of the following standards to develop the safe working load limit .
  - a. ASTM A-563 (A) Grade D Hex Thick  
(B) Grade DH Standard Hex
  - b. SAE Grade 8 Standard Hex
6. Never use free fit spacers or washers between the swivel host ring bushing flange and the mounting surface.
7. Never use swivel hoist rings that show signs of corrosion, wear or damage.
8. Read, understand, and follow the manufacturer's instructions, diagrams, and chart information before using a swivel hoist ring.



#### 10.4.7 Qualification—Eyebolts and Swivel Hoist Rings

While additional supplementary requirements may be specified for a particular application, eyebolts and swivel hoist rings used as rigging hardware must meet the following requirements to be qualified for lifting service. (See para 10.4.1, “Permanently Installed Eyebolts vs. Eyebolts Used as Rigging Hardware.”)

1. Carbon steel eyebolts (ASTM A489) shall have the manufacturer's name or identification mark forged in raised characters on the surface of the eyebolt. Alloy steel eyebolts (ASTM F 541) shall have the symbol “A” (denoting alloy steel) and the manufacturer's name or identification mark forged in raised characters on the surface of the eyebolt.
2. Swivel hoist rings with standard-length bolts are designed for ferrous metal. Long bolts are designed to be used with a soft metal (e.g., aluminum) work piece. Long bolts also may be used with ferrous metal. Leaving the threaded end of a swivel hoist ring under torque in an aluminum work piece will cause stress corrosion in certain aluminum alloys. Therefore, do not leave a swivel hoist ring in aluminum loads for longer than three months. (Depending on the aluminum alloy, a qualified person may allow exceptions to the “three month rule.” Exceptions shall be documented.)
3. Eyebolts and swivel hoist rings shall be of uniform quality consistent with good manufacturing and inspection practices. They shall be free from imperfections which, resulting from their nature, degree, or extent, would make the eyebolt or swivel hoist ring unsuitable for the intended use.
4. Never exceed the SWL of a swivel hoist ring as specified by the manufacturer. When sizing swivel hoist rings used with multiple-leg (non-vertical) rigging, make sure the load angle factor is considered to account for the total load on the swivel hoist ring.

Figure 10-10. Guidelines for Attaching and Using Swivel Hoist Rings.<sup>5</sup>

A. Using Swivel Hoist Rings.

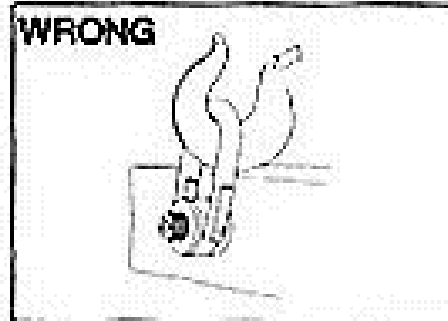
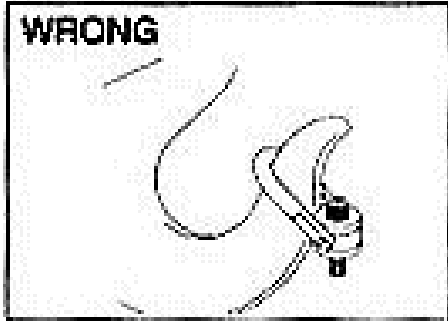

Attach lifting device ensuring free fit to swivel hoist ring bail and ensuring no interference between load (work piece) and bail.

B. Swivel Hoist Ring Inspection Points.

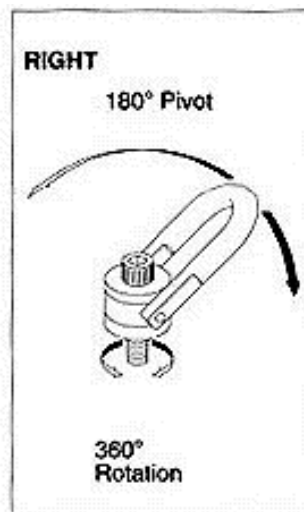

Always ensure free movement of the bail. Never use hoist rings if bail is bent or elongated

C. Rigging Techniques

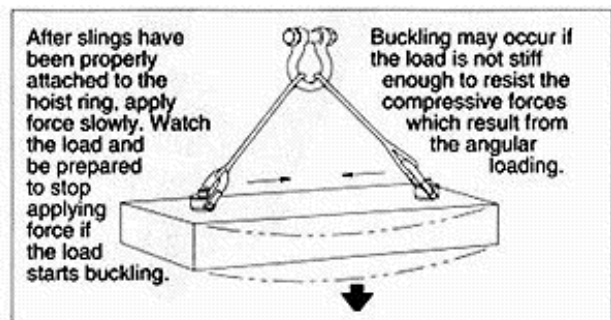
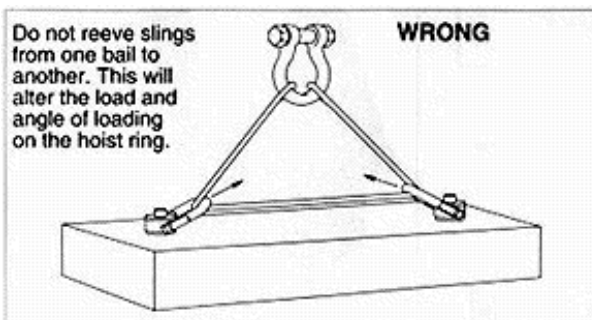

<sup>5</sup> Swivel hoist ring graphics courtesy of The Crosby Group.

## 10.5 TURNBUCKLES

### 10.5.1 General

Requirements and guidelines for turnbuckles are as follows.

1. Turnbuckles shall meet or exceed the requirements of Federal Specification FF-T-791 (latest revision), "Turnbuckles."
2. If turnbuckles are used in a rigging system, that system shall be approved by a qualified engineer or rigging specialist.
3. The minimum design factor for turnbuckles shall be 5:1. A general description of turnbuckles and SWLs of turnbuckles is provided in Fig. 10-11.
4. Turnbuckles used in hoisting and rigging operations shall be fabricated from forged alloy steel.
5. If a turnbuckle is used in an application where vibration is present, the end fittings should be secured to the frame with lock pins or wires to prevent them from turning and loosening (Fig. 10-11). Lock nuts or jam nuts shall not be used.
6. Before placing turnbuckles in critical lifting service, a stamped permanent identification tag similar to the one shown in Fig. 9-7 shall be affixed.

### 10.5.2 Inspection

Inspection criteria for turnbuckles are as follows:

1. Inspect turnbuckles for the following: (Turnbuckle inspection areas are illustrated in Fig. 10-11.)
  - a. Cracks and bends in the frame
  - b. Thread damage and bent rods.
2. Turnbuckles shall be inspected for damage before each use. Damaged threads or bent frame members shall disqualify the unit for use.

### 10.5.3 Testing of Turnbuckles

Turnbuckles used for critical-lift service shall initially be proof tested at twice the rated capacity. Turnbuckles that have been proof tested (at the Hanford Site or by the manufacturer) shall have a tag or other marking to indicate clearly to the user that proof testing has been done.

### 10.5.4 Qualification

Turnbuckles must meet the following requirements to be qualified for lifting service at the Hanford Site.

1. Turnbuckles for critical-lifting service must be initially proof load tested at two times the SWL and tagged or marked (see para 10.5.3, "Testing of Turnbuckles").
2. Turnbuckles shall meet requirements in para 10.5.1, "General," and 10.5.2, "Inspection."

## 10.6 RIGGING HOOKS

### 10.6.1 General

Rigging hooks are used as part of rigging tackle, such as sling assemblies, or with below-the-hook lifting devices. (See Section 5.0, "Hooks," for load hooks on hoists or cranes.) In addition to the typical rigging hooks shown in Figure 10-12, many styles of rigging hooks are available. Some rigging hooks (e.g., grab hooks and sorting hooks) are designed to carry the load near the point as well as in the bowl or saddle of the hook. Maximum safe working loads normally apply only when the load is in the bowl or saddle. Rigging hooks shall be used within the limits specified by the manufacturer. Forged alloy steel hooks generally make the best rigging hooks.

The manufacturer's identification shall be forged or die-stamped on the hook. Except as provided in the following paragraph, loads for rigging hooks shall be equal to or exceed the rated load of the chain, wire rope, or other suspension member to which it is attached. Where this is not feasible, special precautions shall be taken to ensure that the rated load limit of the hook is not exceeded. Welding on hooks, except by the hook manufacturer, is not allowed. Never repair, alter, rework, or reshape a hook by welding, heating, burning, or bending.

Requirements and guidelines for rigging hooks are as follows.

1. Rigging hooks shall meet or exceed the requirements of ANSI/ASME B30.10, *Hooks*, Chapter 10-2, "Hooks, Miscellaneous." (Load hooks are included in Chapter 5.0, "Hooks.")

**NOTE:** Throatlatches are recommended, but consensus standards do not require throatlatches on rigging hooks.

Figure 10-11. Turnbuckle Types, Inspection Areas, and Safe Working Load.

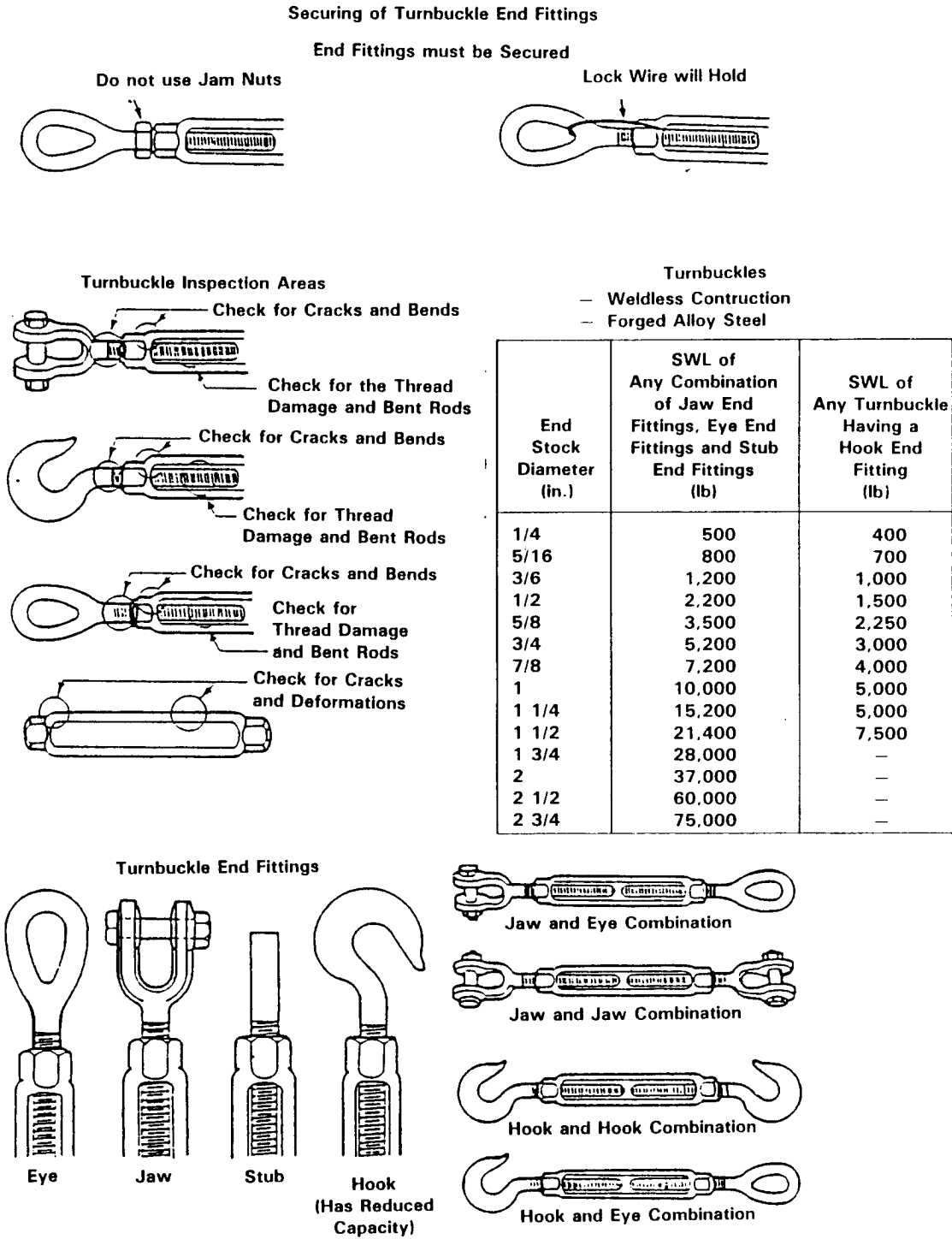

38805-185.26

2. Rigging hooks that do not support a load in a direct-pull configuration, such as grab hooks, sorting hooks, and sling hooks (Fig. 10-12).

3. The SWL for a hook used in the manner for which it is intended shall be equal to or exceed the rated load of the chain, wire rope, or other suspension member to which it is attached.
4. The designated SWL applies only when the load is applied in the bowl or saddle of the hook.
5. The manufacturer's identification shall be forged or die-stamped on a low-stress and nonwearing area of the hook.

### 10.6.2 Inspection

Inspection criteria for rigging hooks are as follows:

1. Rigging hooks that are not permanently installed in a sling assembly shall be visually inspected for the following deficiencies before use:
  - a. Distortions such as bending, or twisting exceeding 10 degrees from the plane of the unbent hook
  - b. Increased throat opening exceeding 15 percent
  - c. Wear exceeding 10 percent of the original dimension
  - d. Cracks, severe nicks, or gouges
  - e. Hook attachment and securing means.
2. Rigging hooks shall be inspected as a part of the slings to which they are attached.
3. The NDT of rigging hooks is not routinely required. Rigging hook NDT may be required by a critical-lift procedure.

Figure 10-12. Miscellaneous Hooks.

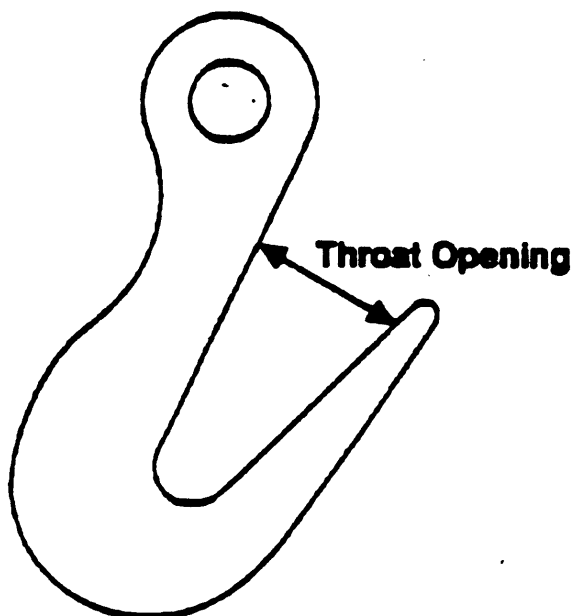

**Sorting Hook**



**Eye Hook**



**Clevis Grab Hook**

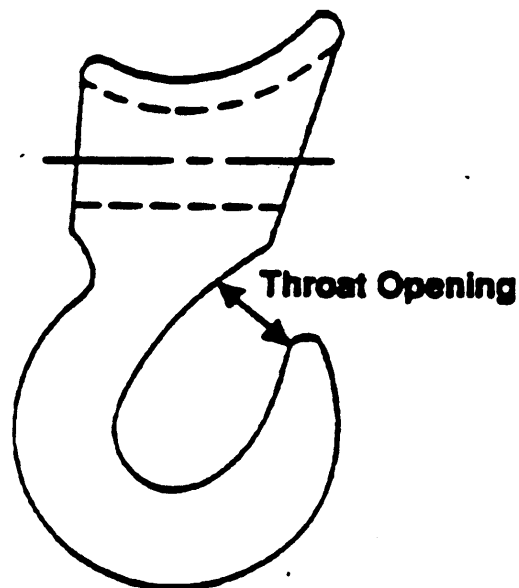

**Choker Hook**