



## FOX Racing Shox Bypass Technical Manual.

The following technical manual will be using a 2.5" dia. shock with three tubes for descriptions and illustrations. Your shock may differ in the number of tubes, or diameter, but the principles and instructions will pertain to all sizes.

### Basic Operation

The external bypass shock functions by allowing a metered amount of oil to flow around the valving piston by way of the tube(s). By allowing some oil to flow around the piston, the damping of the shock will only be a fraction of the total amount of valving on the piston. By controlling the bypass amount with the adjuster, the shock can be broken into small zones, each zone with a different amount of control than the previous. This is only true while the piston is passing thru the bypass circuit or tube. Once the piston has reached the end of the circuit or tube, the effects of that adjuster are no longer effective. If the piston has entered another bypass circuit, then that adjuster is now controlling the bypass. If the piston is passing thru any bypass tube, then there is no bypass, and therefore 100% of the control is coming from the valving on the piston. Typically this area of zero bypass is common in the last 25-30% of travel.

#### Important:

- As the shock is compressing, bypass only occurs from the blue compression tubes.
- As the shock in extending, bypass only occurs from the red rebound tubes.

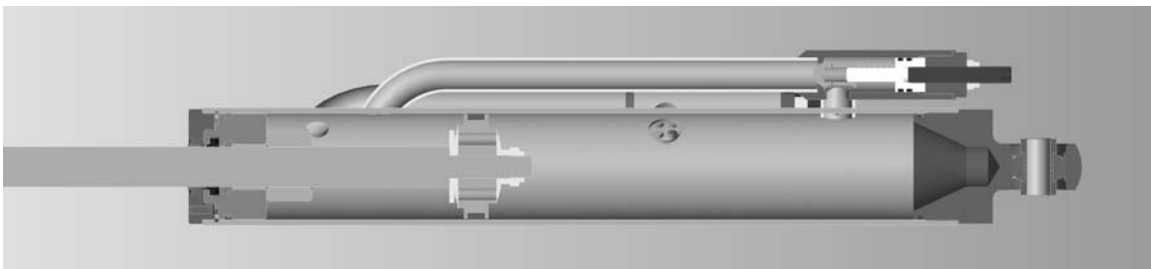

The illustration above show piston is inside the bypass circuit. This is evident because the tube starts where the bend is welded to the body, and ends where the bypass unit is welded to the body.

## Adjuster Breakdown

The bypass unit adjuster consists of a lock nut, adjusting screw, plunger, and check valve. When oil is passed thru the bypass tube, the check valve is pushed back against the plunger, whose depth is determined by the adjusting screw. With the valve in the open position, oil can bypass the piston, the greater the distance between the plunger tip and the valve, the greater the amount of bypass.

The adjuster itself can be adjusted by using a 9/16" wrench to loosen the jam nut, and a 3/16 Allen wrench to turn the adjusting screw in or out. Rotating the screw clockwise will decrease the amount of bypass, by decreasing the travel of the check-valve. Likewise, rotating the screw counter clockwise will increase the amount of bypass.

To determine how far open the adjuster is, loosen the jam nut and count the number of revolutions until the screw is in the full closed position. The adjusting screw may be set in any position to function; however it is easier to keep track of the adjustment if the screw is adjusted in full or half turns. When opening the adjusting screw, the screw will stop when the adjuster reaches the full open position.

The bypass valves are designed to allow flow in only one direction, and therefore can only control flow in one direction. For this reason there are two types of tubes on a bypass shock, a compression tube with a blue cap, and a rebound tube with a red cap. Any adjustments to the compression tubes will not affect the rebound control, and vice-versa.

The figure below shows the adjuster screw set in the full open position, and the valve being kept closed by the spring. Oil that is bypassing would come thru the tube from the left, open the valve, and exit downward.

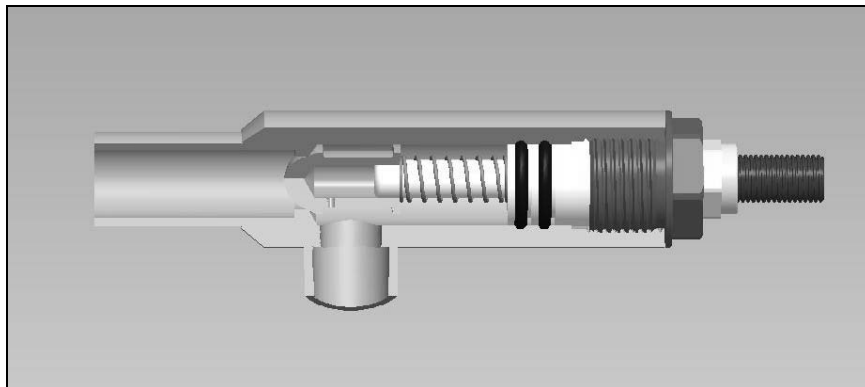

Important:

- When loosening the jam nut, make sure the jam nut breaks free from the cap and not the cap from the housing. It may be necessary to hold the blue or red cap with a 7/8" wrench while loosening the jam nut.
- The Allen adjusting screw should not back all the way out of the bypass unit. If this does occur contact the FOX Racing Shox service department.

## **Shock Service.**

### **Disassembly**

1. Remove the shock spacers from the body cap, and eyelet end of the shock, this will allow you to hold the shock in a vice using a rag to prevent scratching the aluminum.
2. Using a 5/32" Allen wrench, loosen the Allen set screw in the blue bearing cap located on the end of the body.
3. Once the Allen has been loosened, use a 1/4" spanner wrench and loosen the cap (counterclockwise).
4. Discharge the shock, failure in doing so not only will make the shock difficult to disassemble, but could cause serious injury.
5. With the blue bearing cap unthreaded from the bearing, place two hands on the cap and push the cap back down to the body. Doing this will push the bearing down in the body, and allow the snap ring to be removed. Once the bearing has been loosened, slide the cap up the shaft to reveal the internal snap ring. If the cap cannot be pushed in by hand, a soft hammer can be used, however thread the blue cap onto the bearing two or three threads to prevent damage while striking with the hammer.
6. Use a pair of internal snap ring pliers to compress the snap ring for removal. Be careful not to gouge the body during this step with the snap ring or pliers. Any surface scratches may cut the bearing O-ring during disassembly or installation. If a scratch is present, use a Scotch-Brite pad or 600 grit sand paper to smooth out the scratch.
7. Making sure the shock is securely held in the vice and pull up on the eyelet end of the shock. It may be necessary to use your hands in an upward slide-hammer motion to help the O-ring break free from the body of the shock. It may also be helpful to tie a rag around the body to catch any excess oil upon removal of the shaft.
8. With the shock still in the vice, remove the reservoir end cap with the Schrader valve. It may be necessary to tap the cap into the reservoir using a rubber mallet, with the valve cap installed. Using a pair of internal snap ring pliers, compress the snap ring, and remove. Keep in mind that all of the surfaces inside the reservoir are sealing surfaces, and cannot be scratched.
9. Now that the reservoir end cap has been removed, you will be able to see the backside of the Internal Floating Piston (IFP). This IFP separates the Nitrogen

from the oil, and must be set at the proper height during assembly. Use the wooden end of a hammer to push the IFP towards the hose-fitting end. This will push the remaining oil from the reservoir into the shock, allowing all the oil to be dumped at once.

10. Remove the hose-fitting end of the reservoir in the same manner as before. Now that both ends of the reservoir have been removed, the IFP may be removed and cleaned. If changing the IFP O-ring, be careful not to scratch the O-ring gland, doing so may result in an O-ring failure.

***Important:***

*An IFP O-ring failure will also make taking the shock apart impossible. If Nitrogen from the reservoir does get into the oil, the oil will be pressurized, and removing the internal snap ring at the bearing will be impossible. To fix this on a shock with a reservoir hose, simply crack the hose to allow the pressure to escape. To remove the pressure on a piggyback shock, crack open one of the bypass caps with a 7/8" wrench. Be extremely careful when doing this however, because the point when the pressure can escape, and the cap will shoot off, is very close.*

11. To disassemble the bypass unit, loosen the red or blue cap with a 7/8" wrench. Threaded into the cap is the adjuster screw, which is attached to a plunger. These two parts can be pulled out together, being careful not to damage the O-rings on the threads. Beneath the plunger is a small spring, and the check valve, these can be removed with a magnet, or by simply turning the shock upside down.
12. The two O-rings on the plunger should be replaced during a full tear down, and can easily be done with the use of a pick. Be careful not to scratch the O-ring gland with the pick.
13. Place the earlier removed shaft assembly into a vice, making sure to hold on the blue eyelet with a rag or towel to prevent scratching. The piston may be removed with a 3/4" wrench or socket.
14. Carefully remove the damping piston from the shaft assembly, and place on a clean rag or towel. The valve shims may be laid in a row to easily inspect and measure if needed. Be sure to note the order that the valves were removed.
15. Remove the bearing and blue seal cap, careful not to damage the internal seals on the threads that retain the piston.
16. To remove the wiper from the blue bearing cap, use a pick or scribe, and pry inward. Make sure that you do not scratch the gland holding the wiper in.
17. Both the O-ring and U-cup inside the bearing can be removed with a pick or scribe. Once again, stick the pick into the seal, and pry inward towards the center of the bearing, being careful not to scratch the seal glands.
18. Make sure that both that all glands are free from dirt and debris prior to installing new seals.

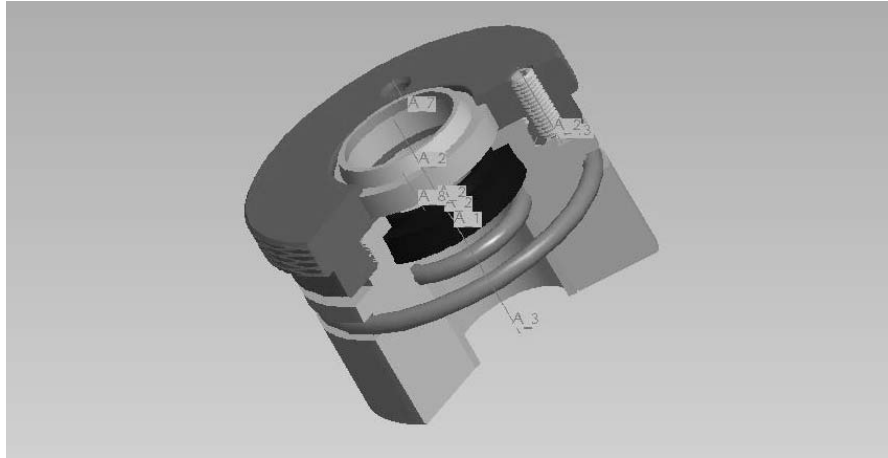

### **ASSEMBLY**

1. At this time re-valve the shock.
2. Re-install the bearing and bearing cap onto the shaft, grease the seals in the bearing, and rock the bearing side-to-side to make installing onto the shaft easier.
3. Once the new valving has been stacked on the piston, and the compression side of the piston has been installed towards the shaft, torque the nut to 30 ft/lbs. The piston nut maybe re-used several times, however the nut should be replaced if you can spin the nut on by hand.
4. Set shaft assembly aside until step 18.
5. Re-install the bypass units into the bypass tubes, in the same order that they were disassembled. First install the bullet shaped check valve, next the spring, widget, and finally the cap. Torque the units to 30 in-lbs.

*For a piggyback shocks, skip to step 10.*

6. Re-install the reservoir hose, and tighten the fitting on the body cap hand tight, and the opposite end with the reservoir end cap should be tightened to 50in-lbs.
7. Place the IFP back into the reservoir, making sure that the O-ring and wear band are installed. Set the surface of the IFP w/o the threads five inches from the top.
8. Add oil to reservoir on top of the IFP. The oil side is the side w/o the threads.
9. Insert the reservoir end cap into the reservoir making sure that the end cap O-ring is re-installed. The O-ring should be wiped with shock oil to ease installation.
10. Using internal snap ring pliers, re-install the snap ring, to retain the previously installed reservoir end cap.
11. With the shock still in the vice, let the reservoir drop below the body cap to allow any air to rise to the surface. Next, with the reservoir still below the body cap, push the IFP until it tops out on the reservoir end cap, this will completely fill the hose with oil, and remove air from the reservoir and hose.

*For non-piggyback shocks, skip to step 17.*

12. With the shock still in the vice, slide the reservoir over the end cap that is attached to the welded fitting on the shock, making sure that the end cap O-ring is re-installed. The O-ring should be wiped with shock oil to ease installation.
13. For piggyback shocks, place the IFP back into the reservoir, making sure that the O-ring and wear band are installed. If your reservoir is 2.0" in diameter, push the IFP all the way to the top. If your reservoir is 2.5" in diameter, set the IFP eleven inches from the bottom
14. Using internal snap ring pliers, re-install the snap ring into the reservoir, (to retain the previously installed reservoir end cap), and then pull the reservoir down to seat the O-ring.
15. Secure the other end of the reservoir with the provided hose clamp. *Over tightening the hose clamp can distort the shape of the reservoir.*
16. Fill the shock with oil until it appears that oil has filled the reservoir and reservoir tube. At this point, air trapped in the rebound tubes can be bled out by simply placing your hand over the base of the shock and flipping the shock over. You will be able to hear the bubbles rising to the surface. Make sure you have a good seal with your hand before flipping over the shock to avoid a big mess.
17. Place shock into vice using rag to protect the aluminum.
18. Now that all of the air has been bled from the system, insert the shaft assembly into oil to bleed the air from the valves. At this point, all the bypass tubes should be in the full open position.
19. Begin slowly pushing the shaft in and out of the oil to remove air trapped in and behind the valves. You will know you are finished with the bleeding when bubbles no longer rise to the surface.

**Important:**

If you are bleeding a piggyback shock, you can bleed the shock without worrying about the IFP moving as you push the shaft inward. However, if you are bleeding a reservoir shock, be careful not to push too hard while bleeding, because rather than the oil going thru the valves, the IFP will get pushed back into the reservoir. One way to avoid this is to fully assemble the reservoir, and charge it with 10-20 psi. This will insure that as you bleed the shock, the IFP will not move. Also, if bleeding a reservoir shock, if the hose fittings are not tight, air will continue to be drawn in, and the bubbles will never stop rising.

20. Once you feel confident that all the air is out of the shock, pull the shaft up until the first Al spacer is flush with the top of the shock body. The oil level should be just covering the top of the second spacer. Slide the bearing down until it contacts the Al spacer, and then slowly push the whole assembly into the body. As the bearing is pushed into the body, any excess oil will escape thru the groove on the bearing. If no oil comes out, this means that you did not have enough oil in the shock to start with, and now an air pocket is trapped inside the shock, and needs to be re-bled.

21. Now that the bearing is installed, slide the blue cap down again till it contacts the bearing. Push the cap down until it hits the body, this will push the bearing down even further, allowing access to the snap ring groove.
22. Install the snap ring into the groove, and clean off any excess oil residue.
23. Charge shock with 200 psi. of nitrogen. Failing to do so will allow the bearing to rotate during next step, and cap will not get tight.
24. Tighten blue bearing cap with spanner wrench, and lock in place by tightening set screw with 5/32" Allen wrench.
25. Once the shock has been completely re-assembled and charged, check for leaks.

COMPRESSION DAMPING																				
VALVE OUTSIDE DIA.	#30	#35	#40	#45	#50	#55	#60	#65	#70	#75	#80	#85	#90	#95	#100	#105	#110	#115	#120	
Ø 1.800"	0.008	0.008	0.008	0.008	0.010	0.010	0.010	0.010	0.012	0.012	0.012	0.012	0.015	2 X .010	2 X .012	2 X .015	3 X .015	4 X .015	4 X .015	
Ø 1.600"	0.008	0.008	0.008	0.01	0.010	0.010	0.010	0.012	0.012	0.012	0.012	0.015	0.015	2 X .010	2 X .012	2 X .015	2 X .015	2 X .015	3 X .015	
Ø 1.425"	0.008	0.008	0.010	0.010	0.010	0.010	0.012	0.012	0.012	0.012	0.015	0.015	0.015	0.015	0.015	0.015	0.015	0.015	2 X .015	
Ø 1.350"	0.008	0.010	0.010	0.010	0.010	0.012	0.012	0.012	0.012	0.015	0.015	0.015	0.015	0.015	0.015	0.015	0.015	0.015	0.015	
Ø 1.100"	0.008	0.010	0.010	0.010	0.010	0.012	0.012	0.012	0.012	0.015	0.015	0.015	0.015	0.015	0.015	0.015	0.015	0.015	0.015	
Ø .950"	0.008	0.010	0.010	0.010	0.010	0.012	0.012	0.012	0.012	0.015	0.015	0.015	0.015	0.015	0.015	0.015	0.015	0.015	0.015	
Ø .800"	0.020	0.020	0.020	0.020	0.020	0.020	0.020	0.020	0.020	0.020	0.020	0.020	0.020	0.020	0.020	0.020	0.020	0.020	0.020	
Ø1.57" TOP OUT	0.128	0.128	0.128	0.128	0.128	0.128	0.128	0.128	0.128	0.128	0.128	0.128	0.128	0.128	0.128	0.128	0.128	0.128	0.128	
REBOUND DAMPING																				
VALVE OUTSIDE DIA.	#30	#35	#40	#45	#50	#55	#60	#65	#70	#75	#80	#85	#90	#95	#100	#105				
Ø 1.600"	0.008	0.008	0.008	0.008	0.010	0.010	0.010	0.010	0.012	0.012	0.012	0.012	0.015	2 X .010	2 X .012	2 X .015				
Ø 1.425"	0.008	0.008	0.008	0.010	0.010	0.010	0.010	0.012	0.012	0.012	0.012	0.015	0.015	2 X .010	2 X .012	2 X .015				
Ø 1.350"	0.008	0.008	0.010	0.010	0.010	0.010	0.012	0.012	0.012	0.012	0.015	0.015	0.015	0.015	0.015	0.015				
Ø 1.100"	0.008	0.008	0.010	0.010	0.010	0.012	0.012	0.012	0.012	0.015	0.015	0.015	0.015	0.015	0.015	0.015				
Ø .950"	0.008	0.010	0.010	0.010	0.010	0.012	0.012	0.012	0.012	0.015	0.015	0.015	0.015	0.015	0.015	0.015				
Ø .800"	0.008	0.010	0.010	0.010	0.010	0.012	0.012	0.012	0.012	0.015	0.015	0.015	0.015	0.015	0.015	0.015				
Ø .750" BACK UP	0.200	0.200	0.200	0.200	0.200	0.200	0.200	0.200	0.200	0.200	0.200	0.200	0.200	0.200	0.200	0.200				

## Valving

The bypass shock offers a large range of adjustment that can easily be changed externally on the shock. However, there is no amount of adjustment that can help a shock that has the incorrect valving to start with. If you have closed all of the adjusters, and you shock still feel to soft, then you probably need to increase the valving on the piston itself.

Likewise, if all the adjusters are wide open, and the shock feels to stiff, then you probably need to remove valving from the piston.

The valving that the shocks left the factory with is engraved into the lower eyelet just under the black bottom-out bumper. The eyelet shown below has a valving of 50/70, where the first number is the compression value, and the second is the rebound value. The numbers have no physical value; they only correspond with the numbers on the chart above. Do not think that a #70 stack is 10% heavier than a #60 stack, nor is a #60 stack twice as stiff a #30 stack. Use the numbers only to convey what valve stack is in the shock.

