

polk audio®

DB351  
3 1/2" Coaxial

DB401  
4" Coaxial

DB461  
4" x 6" Coaxial

DB461P  
4" x 6" Plate

DB501  
5" Coaxial

DB521  
5 1/4" Coaxial

DB571  
5" x 7" Coaxial

DB651  
6 1/2" Coaxial

DB651S  
Slim Mount Coaxial

DB691  
6" x 8" Three-Way

DB5251  
5 1/4" Component System

DB6501  
6 1/2" Component System

DB1001  
1" Tweeter

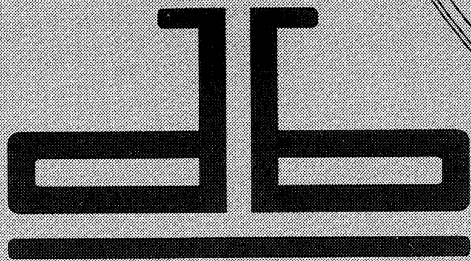

Owner's Manual

## ENGLISH

---

### Getting Started

Please inspect your loudspeakers carefully. Notify your Polk Audio dealer if you notice any damage or missing items. Keep the carton and packing material; this will do the best job of protecting your loudspeakers if they must be transported.

### Safe Limits of Operation

Damage to loudspeakers can occur when an amplifier, regardless of its wattage, is made to play at higher listening levels than it can produce at low distortion levels. This is usually beyond the "noon or 1 o'clock" position on the volume control. Operation at this level can result in very high levels of audible distortion originating in the amplifier, which can add a harsh, gritty sound to your listening material. Contrary to popular belief, a loudspeaker is more likely to be damaged by trying to get too much volume from a low-powered amplifier or receiver than from a high-powered one.

### Technical Assistance or Service

If, after following the hookup directions, you experience difficulty, please double-check all wire connections. Should you isolate the problem to the loudspeaker, contact the authorized Polk Audio dealer where you made your purchase, or contact Polk Audio Customer Service 800-377-7655 (M-F, 9-6 EST, US only) or via email [polkcs@polkaudio.com](mailto:polkcs@polkaudio.com). Outside the US, call 410-358-3600.

More detailed information—including audio how-to articles, FAQs, and online manuals—is available on our award-winning website [www.polkaudio.com/car](http://www.polkaudio.com/car).

## ESPAÑOL

---

### Inicio

Inspeccione cuidadosamente los altavoces. Comuníquese con su distribuidor de Polk Audio si falta alguna pieza o si hay alguna pieza dañada. Guarde la caja de cartón y el material de empaquetado; son lo mejor para proteger los altavoces si hay que transportarlos.

### Límites seguros de funcionamiento

Los altavoces se pueden dañar cuando se hace funcionar un amplificador, independientemente de su potencia en vatios, a más volumen del que puede producir a bajos niveles de distorsión. Esto ocurre por lo general cuando el control de volumen, visto como si fuera la manecilla que marca las horas en un reloj, se pasa de la posición de las 12 o de la 1. El funcionamiento a este volumen puede producir altos niveles de distorsión audible originada en el amplificador, lo cual puede agregar un sonido discordante y arenoso a lo que se está escuchando. Al contrario de lo que se cree por lo general, es más probable que los altavoces se dañen intentando extraer demasiado volumen de un amplificador o receptor de poca potencia que de uno de alta potencia.

### Asistencia o servicio técnico

Si después de seguir las instrucciones de conexión usted sigue teniendo dificultades, vuelva a comprobar todas las conexiones de cables. Si logra aislar el problema en el altavoz, comuníquese con el distribuidor autorizado de Polk Audio donde compró el altavoz o con el Servicio al Cliente de Polk Audio llamando al 800-377-7655 (de lunes a viernes de 9 a.m. a 6 p.m., hora estándar del Este, sólo en EE.UU.) o por correo electrónico a [polkcs@polkaudio.com](mailto:polkcs@polkaudio.com). Fuera de los EE.UU., llame al 410-358-3600.

Hay artículos sobre cómo hacer las cosas en audio, preguntas frecuentes y manuales en línea en nuestro galardonado sitio Web [www.polkaudio.com/car](http://www.polkaudio.com/car).

## FRANÇAIS

---

### Guide de démarrage

Inspectez vos haut-parleurs avec soin. Si vous constatez des dommages ou s'il manque des pièces, contactez votre revendeur Polk Audio. Conservez la boîte et l'emballage—they assureront la meilleure protection de vos haut-parleurs en cas de transit éventuel.

### Limites d'opération

Un haut-parleur peut être endommagé lorsqu'un amplificateur, quelle que soit sa puissance, est poussé au delà de ses limites (typiquement à la position 12h ou 13h du contrôle de volume). L'amplificateur surchargé génère alors un niveau élevé de distorsion et le son devient rauque et éraillé. Contrairement à ce qu'on puisse penser, un haut-parleur peut-être endommagé plus facilement par un amplificateur de faible puissance poussé au delà de ses limites que par un amplificateur de haute puissance.

### Service ou assistance technique

Si, après avoir suivi toutes les instructions, vous éprouvez des difficultés, vérifiez toutes vos connexions. Si vous en concluez que le problème est relié au haut-parleur, communiquez avec votre revendeur Polk Audio ou contactez le Service à la Clientèle de Polk Audio au 1-800-377-7655 (L-V, 9-18, HNE, Canada et É.-U. seulement). À l'extérieur des É.-U. et du Canada, composez le 410-358-3600. Vous pouvez aussi nous contacter par courriel à l'adresse: [polkcs@polkaudio.com](mailto:polkcs@polkaudio.com).

Pour plus d'information—including des chroniques pratiques, des FAQ et des manuels d'utilisation en ligne, visitez notre site web primé: [www.polkaudio.com/car](http://www.polkaudio.com/car).

## DEUTSCH

---

### Erste Schritte

Inspizieren Sie bitte Ihre Lautsprecher sorgfältig. Verständigen Sie Ihren Polk Audio-Fachhändler, falls Sie Schäden oder fehlende Teile bemerken. Behalten Sie den Karton und das Verpackungsmaterial, da diese Ihre Lautsprecher bei einem etwaigen Transport am besten schützen.

### Sichere Betriebsgrenzen

Wenn ein Verstärker, ungeachtet seiner Leistung in Watt, lautere Musik abspielt, als er bei niedriger Verzerrung produzieren kann, kann dies die Lautsprecher beschädigen. Dies ist meist höher als die 12- oder 1-Uhr-Position des Lautstärkereglers. Bei einem Betrieb mit dieser Lautstärke kann der Verstärker sehr hohe, hörbare Verzerrungen erzeugen, welche die Musik rau und grob klingen lassen können. Entgegen der verbreiteten Ansicht ist es wahrscheinlicher, dass ein Lautsprecher dadurch beschädigt wird, dass man zu viel Lautstärke aus einem schwachen Verstärker oder Receiver herausholen will, als dass man einen zu starken verwendet.

### Technischer Kundendienst und Service

Wenn Sie Probleme haben, nachdem Sie den Installationsanweisungen gefolgt sind, sollten Sie alle Kabelverbindungen nochmals prüfen. Wenn Sie zu dem Schluss kommen, dass das Problem am Lautsprecher liegt, kontaktieren Sie bitte den autorisierten Polk Audio-Händler, bei dem Sie den Lautsprecher gekauft haben, oder rufen den Polk Audio-Kundendienst unter 800-377-7655 (M-F, 9-18 Uhr US-Ostküstenzeit, nur USA) an oder senden eine E-Mail an [polkcs@polkaudio.com](mailto:polkcs@polkaudio.com). Von außerhalb der USA rufen Sie +1 410-358-3600 an.

Detaillierte Anweisungen, Antworten auf häufig gestellte Fragen und Online-Handbücher finden Sie auf der preisgekrönten Website [www.polkaudio.com/car](http://www.polkaudio.com/car).

## PORTUGUÊS

---

### Primeiros passos

Inspeccione cuidadosamente cada alto-falante. Notifique o revendedor da Polk Audio caso note algum dano ou caso estiver faltando algum componente. Guarde a caixa e o material de embalagem, pois são mais adequados para proteger os alto-falantes caso precisem ser transportados.

### Limites seguros de operação

Os alto-falantes podem ser danificados quando um amplificador, independentemente de sua potência, for operado a níveis de reprodução mais elevados do que consegue produzir a níveis baixos de distorção. Esta posição é geralmente após a posição correspondente ao “meio-dia ou 1 hora” no controle de volume. A operação nesse volume pode resultar em níveis muito elevados de distorção audível a partir do amplificador, o que pode acrescentar um som desarmonioso e estridente ao áudio sendo reproduzido. Ao contrário do que se pensa, é mais fácil danificar um alto-falante ao tentar maximizar o volume a partir de um amplificador ou receiver de baixa potência do que de um de alta potência.

### Ajuda ou assistência técnica

Se tiver alguma dificuldade depois de seguir as orientações de instalação, verifique as conexões dos cabos. Caso consiga isolar o problema ao alto-falante, entre em contato com o revendedor autorizado Polk Audio onde adquiriu o produto ou com o Serviço de Atendimento ao Cliente da Polk Audio ligando para 1-800-377-7655 (de segunda a sexta-feira, das 9h00 às 18h00 do horário de Nova York—apenas nos EUA) ou por e-mail pelo endereço [polkcs@polkaudio.com](mailto:polkcs@polkaudio.com). Caso esteja em outro país, ligue para 1-410-358-3600.

Nosso website premiado contém informações mais detalhadas, incluindo artigos informativos com procedimentos passo a passo, perguntas frequentes e manuais eletrônicos. Para obter essas e outras informações sobre áudio, visite [www.polkaudio.com/car](http://www.polkaudio.com/car).

## ITALIANO

---

### Per iniziare

Ispezionare i diffusori attentamente e avvisare il rivenditore Polk Audio se si rilevano componenti danneggiati o mancanti. Conservare la scatola e il materiale d'imballaggio, che serviranno a proteggere i diffusori nel modo migliore se devono essere trasportati.

### Limiti di sicurezza in relazione al funzionamento

Un diffusore può subire danni se si fa funzionare un amplificatore, indipendentemente dalla sua potenza nominale, a livelli di ascolto più alti di quelli che può produrre a bassi livelli di distorsione; in genere ciò si verifica quando si gira il comando del volume oltre la posizione corrispondente alle 12-13 di un orologio immaginario. In tali casi il funzionamento può causare livelli molto alti e udibili della distorsione che si genera nell'amplificatore, e che possono aggiungere tonalità stridenti ai suoni che si ascoltano. Al contrario di quanto si ritiene comunemente, un diffusore ha più probabilità di subire danni se si cerca di ottenere un volume eccessivo con un amplificatore o ricevitore a bassa potenza anziché con uno ad alta potenza.

### Servizio di assistenza

Se dopo aver seguito le istruzioni per il collegamento si hanno problemi, controllare di nuovo tutte le connessioni. Una volta isolato il problema al diffusore, contattare il rivenditore Polk Audio presso cui lo si è acquistato o il centro di assistenza Polk Audio al numero 800-377-7655 (lunedì-venerdì, dalle 09.00 alle 18.00, fuso orario EST, solo negli Stati Uniti) o per e-mail all'indirizzo [polkcs@polkaudio.com](mailto:polkcs@polkaudio.com). Fuori degli Stati Uniti chiamare il numero 001-410-358-3600.

Per ulteriori informazioni, tra cui articoli pratici sui sistemi audio, domande frequenti (FAQ) e manuali online, visitare il nostro sito Web [www.polkaudio.com/car](http://www.polkaudio.com/car).

**Figure 1**  
BASIC COAXIAL CONNECTION

**Figura 1**  
CONEXIÓN COAXIAL BÁSICA

**Figure 1**  
CONNEXION D'UN HAUT-  
PARLEUR COAXIAL

**Abbildung 1**  
EINFACHE KOAXIALVERBINDUNG

**Figura 1**  
CONEXÃO COAXIAL BÁSICA

**Figura 1**  
CONNESSIONE COASSIALE DI BASE

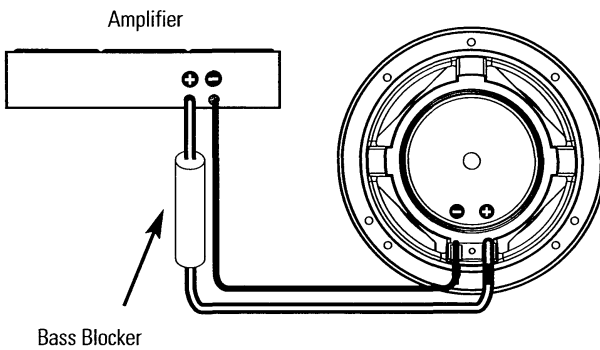
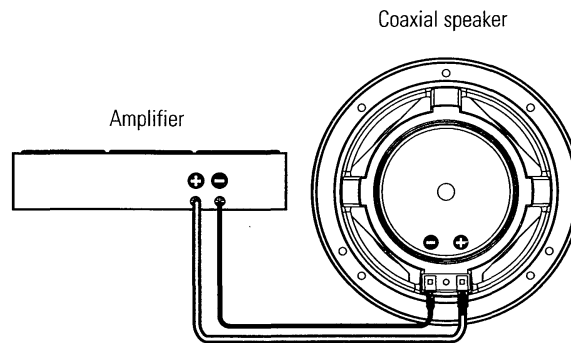

**Figure 2**  
BASS BLOCKER db351 WIRING CONNECTION

**Figura 2**  
BLOQUEADOR DE BAJOS  
CONEXIÓN DE CABLEADO DEL db351

**Figure 2**  
«BASS BLOCKER» (bloqueur de graves)  
CONNEXION: db351

**Abbildung 2**  
BASS-BLOCKIEREINHEIT  
db351-VERKABELUNGSANSCHLUSS

**Figura 2**  
BLOQUEADOR DE GRAVES CONEXÃO do db351

**Figura 2**  
FILTRO PASSA ALTO CABLAGGIO DEL db351

**Figure 3**  
BASIC COMPONENT CONNECTION  
INSTALLING db5251& db6501

**Figura 3**  
CONEXIÓN DE COMPONENTES  
BÁSICOS INSTALACIÓN DE  
LOS MODELOS db5251 Y db6501

**Figure 3**  
CONNEXION DES COMPOSANTS  
INSTALLATION: db5251 / db6501

**Abbildung 3**  
EINFACHE KOMPONENTENVERBINDUNG  
INSTALLATION VON db5251& db6501

**Figura 3**  
CONEXÃO BÁSICA DOS COMPONENTES  
INSTALAÇÃO DO db5251 e db6501

**Figura 3**  
CONNESSIONE COMPONENTI DI BASE  
INSTALLAZIONE DEL db5251e db6501

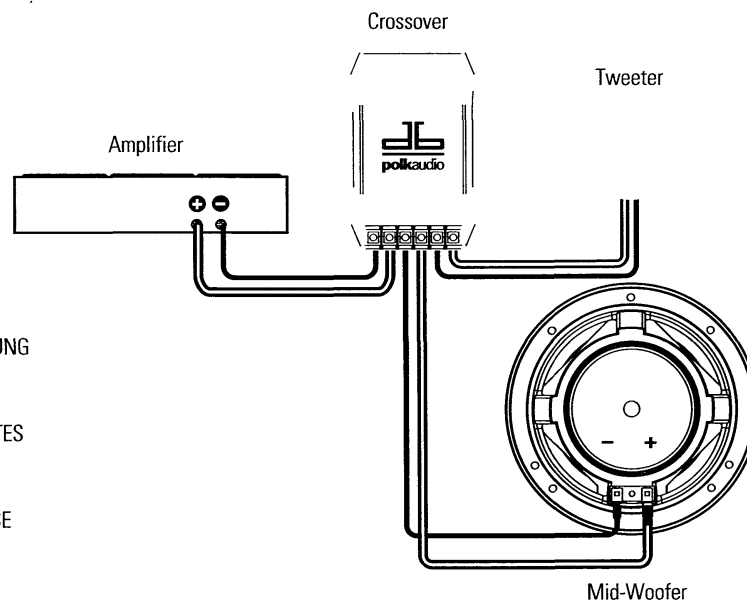

**Figure 4**  
 INSTALLING db351  
 ROUND MODEL

**Figura 4**  
 INSTALACIÓN DEL MODELO  
 REDONDO db351

**Figure 4**  
 INSTALLATION: db351  
 MODÈLE ROND

**Abbildung 4**  
 INSTALLATION VON db691  
 OVALES MODELL

**Figura 4**  
 INSTALAÇÃO DO db351  
 MODELO REDONDO

**Figura 4**  
 INSTALLAZIONE DEL db351  
 MODELLO CIRCOLARE

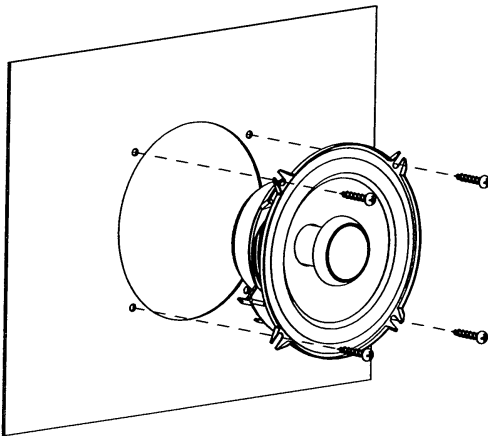
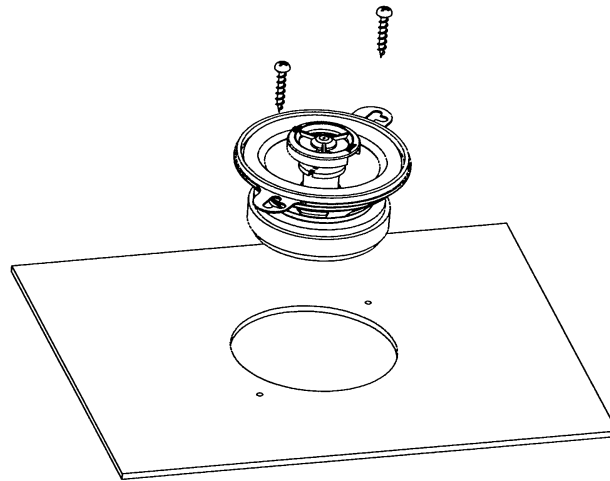

**Figure 5**  
 INSTALLING db401, db501, db521, db651,  
 db651s, db5251, db6501 ROUND MODELS

**Figura 5**  
 INSTALACIÓN DE LOS MODELOS REDONDOS db401,  
 db501, db521, db651, db651s, db5251 Y db6501

**Figure 5**  
 INSTALLATION: db401, db501, db521, db651,  
 db651s, db5251, db6501 MODÈLES ROUNDS

**Abbildung 5**  
 INSTALLATION VON db401, db501, db521, db651,  
 db651s, db5251, db6501 RUNDE MODELLE

**Figura 5**  
 INSTALAÇÃO DO db401, db501, db521, db651,  
 db651s, db5251, db6501 MODELOS REDONDOS

**Figura 5**  
 INSTALLAZIONE DEL db401, db501, db521, db651,  
 db651s, db5251, db6501 MODELLI CIRCOLARI

**Figure 6**  
 INSTALLING db461, db461p, db571,  
 OVAL MODELS

**Figura 6**  
 INSTALACIÓN DE LOS MODELOS OVALADOS  
 db461, db461p Y db571

**Figure 6**  
 INSTALLATION: db461, db461p, db571,  
 MODÈLES OVALES

**Abbildung 6**  
 INSTALLATION VON db461, db461p, db571,  
 OVALE MODELLE

**Figura 6**  
 INSTALAÇÃO DOS MODELOS OVAIS  
 db461, db461p, db571

**Figura 6**  
 INSTALLAZIONE DEL db461, db461p, db571,  
 MODELLI OVALI

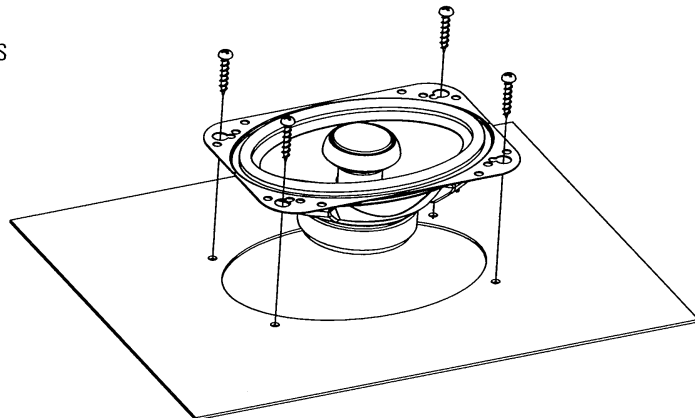

**Figure 7**  
INSTALLING db691  
OVAL MODEL WITH GRILLE

**Figura 7**  
INSTALACIÓN DEL MODELO  
OVALADO db691 CON REJILLA

**Figure 7**  
INSTALLATION: db691  
MODÈLE OVALE avec grille

**Abbildung 7**  
INSTALLATION VON db691  
OVALES MODELL mit Grill

**Figura 7**  
INSTALAÇÃO DO db691  
MODELO OVAL com grade

**Figure 7**  
INSTALLAZIONE DEL db691  
MODELLO OVALE con griglia

Remove bottom mount spacer ring before installing grille.

Quite el anillo espaciador de la montura de abajo antes de instalar la rejilla.

Retirez la bague d'espacement conçue pour montage en dessous du panneau avant d'installer la grille.

Vor Installation des Grills unteren Zwischenring entfernen.

Retire o anel espaçador de instalação inferior antes de instalar a grade.

Rimuovere il distanziale di fissaggio inferiore prima di installare la griglia.

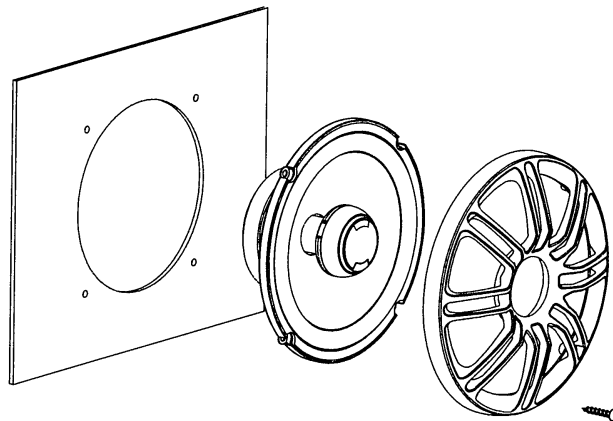
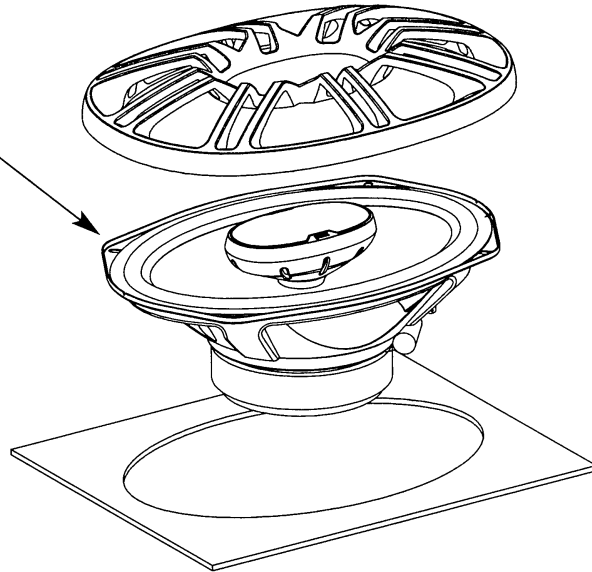

**Figure 8**  
INSTALLING db401, db521, db5251,  
ROUND MODELS WITH GRILLE

**Figura 8**  
INSTALACIÓN DE LOS MODELOS REDONDOS  
db401, db521 Y db5251 CON REJILLA

**Figure 8**  
INSTALLATION: db401, db521, db5251,  
MODÈLES RONDS AVEC GRILLE

**Abbildung 8**  
INSTALLATION VON db401, db521, db5251,  
RUNDE MODELLE MIT GRILL

**Figura 8**  
INSTALAÇÃO DO db401, db521, db5251,  
MODELOS REDONDOS COM GRADE

**Figure 8**  
INSTALLAZIONE DEL db401, db521, db5251  
MODELLI CIRCOLARI CON GRIGLIA

**Figure 9**

INSTALLING db651s, db651 & db6501  
WITH GASKET AND GRILLE

**Figura 9**

INSTALACIÓN DE LOS MODELOS db651s,  
db651 Y db6501 CON JUNTA Y REJILLA

**Figure 9**

INSTALLATION: db651s, db651, db6501  
avec JOINT D'ÉTANCHÉITÉ et GRILLE

**Abbildung 9**

INSTALLATION VON db651s, db651  
& db6501 MIT DICHTUNG und Grill

**Figura 9**

INSTALAÇÃO DO db651s, db651 e db6501  
COM GAXETA e grade

**Figura 9**

INSTALLAZIONE DEL db651s, db651 e  
db6501 CON GUARNIZIONE e griglia

**Figure 10**

INSTALLING db6501/db651 WITH GRILLE  
Some applications may require using the  
additional spacer/adaptor bracket.

**Figura 10**

INSTALACIÓN DE LOS MODELOS db6501  
Y db651 CON REJILLA

Algunas aplicaciones pueden requerir el soporte espaci-  
ador/adaptador adicional

**Figure 10**

INSTALLATION : db6501/db651 avec grille  
En certains cas, un support adaptateur-espaceur  
pourrait être requis.

**Abbildung 10**

INSTALLATION VON db6501/db651 mit Grill  
In manchen Fällen muss ein zusätzlicher Abstandsring-  
Adapter verwendet werden.

**Figura 10**

INSTALAÇÃO DO db6501/db651 com grade  
Algumas aplicações podem exigir o uso de outro  
espaçador/suporte adaptador.

**Figura 10**

INSTALLAZIONE DEL db6501/db651 con griglia  
In alcuni casi può essere necessario adoperare la staffa  
di adattamento/distanziatrice.

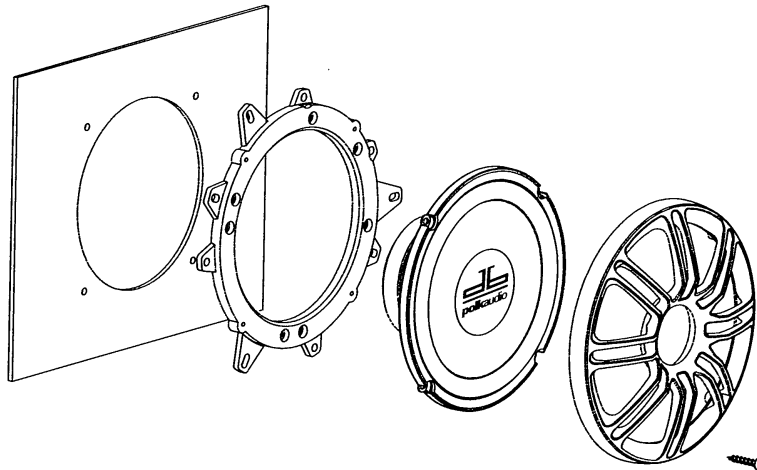



**Figure 11**

**CROSSOVER MOUNTING**

Allow for ventilation clearance.

**Figura 11**

**MONTAJE DE CROSSOVER**

Deje espacio para la ventilación

**Figure 11**

**MONTAGE DU SÉPARATEUR**

Assurez un dégagement suffisant pour la ventilation.

**Abbildung 11**

**CROSSOVER-INSTALLATION**

Lassen Sie Freiraum zur Lüftung.

**Figura 11**

**MONTAGEM DO CROSSOVER**

Deixar espaço para ventilação.

**Figura 11**

**FISSAGGIO DEL CROSSOVER**

Lasciare spazio sufficiente per la circolazione dell'aria.

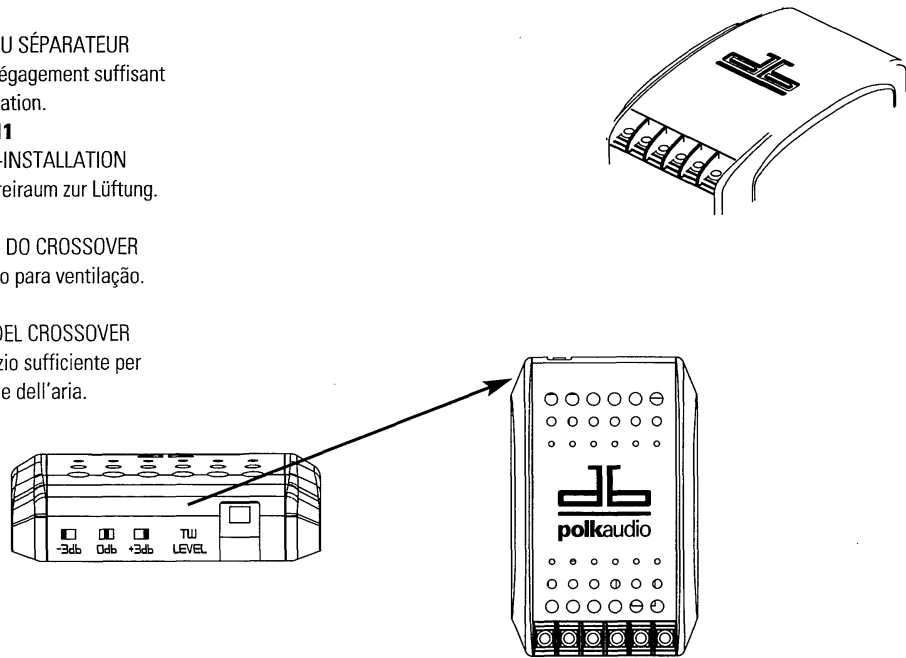

**Figure 12**

**TWEETER ATTENUATION SWITCH**

A 3-position switch (-3dB, 0dB, +3dB ) allows you to adjust tweeter level for the tonal balance that's right for your car and system.

**Figura 12**

**SELECTOR DE ATENUACIÓN DE TWEETER**

El selector de 3 posiciones (-3dB, 0dB, +3dB ) permite ajustar el nivel de tweeter a fin de producir el balance tonal correcto para su automóvil y su sistema.

**Figure 12**

**COMMUTEUR D'ATTÉNUATION DU TWEETER**

Un commutateur à trois positions (-3dB, 0dB, +3dB ) vous permet d'ajuster le niveau du tweeter selon vos préférences et l'acoustique de votre voiture.

**Abbildung 12**

**HOCHTÖNERABSCHWÄCHUNGS-SCHALTER**

Dieser Schalter mit 3 Positionen (-3 dB, 0 dB, +3 dB ) ermöglicht es Ihnen, den Hochtönerpegel auf den für Ihr Auto und Ihr System richtigen Wert einzustellen.

**Figura 12**

**CHAVE DE ATENUAÇÃO DO TWEETER**

Uma chave de três posições (-3dB, 0dB, +3dB) permite que o nível de sinal do tweeter seja ajustado para obter o equilíbrio tonal correto para seu veículo e sistema.

**Figure 12**

**COMANDO DI ATTENUAZIONE TWEETER**

Un selettore a tre posizioni (-3 dB, 0 dB, +3 dB ) permette di regolare il livello del tweeter per ottenere il bilanciamento dei toni adatto all'autoveicolo e all'impianto.

**Figure 13**

**TWEETER ATTENUATION WIRE LOOP**

Cut this wire to reduce tweeter level 3dB.

**Figura 13**

**BUCLE CONDUCTOR DE ATENUACIÓN DE TWEETER**

Corte este conductor para reducir el nivel de tweeter en 3dB.

**Figure 13**

**BOUCLE DE FIL POUR ATTÉNUATION DU TWEETER**

Coupez ce fil pour réduire le niveau du tweeter de 3dB.



**Abbildung 13**

**HOCHTÖNERABSCHWÄCHUNGS-DRAHTSCHLAUFE**

Schneiden Sie diesen Draht durch, um den Hochtönerpegel um 3dB zu senken.

**Figura 13**

**LOOP DE ATENUAÇÃO DO TWEETER**

Corte este fio para reduzir o nível de sinal do tweeter em 3dB.

**Figure 13**

**ANELLO CONDUTTORE DI ATTENUAZIONE TWEETER**

Tagliare questo cavo per ridurre il livello del tweeter di 3dB.

## ENGLISH

### DB6501 & DB5251

**Figure 14**  
**Flush Mount**

#### TWEETER MOUNTING

1. Check for proper clearance: The flush mount kit is 7/8" (22.2mm) deep.
2. Mark the center of the spot and cut a 2" (50.8mm) diameter hole using a hole saw, drill bit or razor knife.
3. Assemble the cup, clamp and machine screw loosely as shown.
4. Route wires through the round opening in the bottom of the cup.
5. Press the assembly into the 2" (50.8mm) diameter hole until the clamp edge is below the mounting surface, then tighten the screw. The legs of

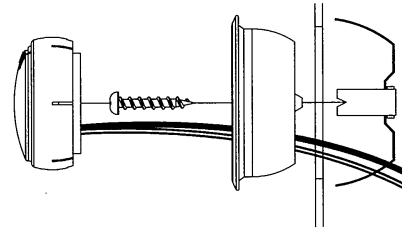

the clamp can be bent outward by inserting a screwdriver through the holes in the cup while still mounted.

6. Connect wires from the tweeter terminals of the Crossover to the tweeter itself using the faston connectors. Connect the red wire from the (+) terminal of the Crossover tweeter output to the red (+) wire from the tweeter.
7. Mount the tweeter by snapping it into the mounting cup.

## ESPAÑOL

**Figura 14**  
**Montaje al ras**

#### MONTAJE DEL TWEETER

1. Verifique que haya suficiente espacio: el juego de montaje al ras tiene 22.2 mm (7/8 de plg.) de profundidad.
2. Marque el punto central del área donde va a quedar el tweeter y haga un agujero de 50.8 mm (2 plg.) con una sierra caladora, una broca perforadora o un cuchillo utilitario.
3. Arme la copa, la abrazadera y los tornillos para metales sin apretarlos, tal como se muestra.
4. Encamine los cables a través de la abertura redonda que hay en la base de la copa.

5. Presione la unidad para que entre en el agujero de 50.8 mm (2 plg.) hasta que el borde de la abrazadera quede debajo de la superficie de montaje, luego apriete los tornillos. Las patas de la abrazadera se pueden doblar hacia afuera insertando un destornillador a través de los agujeros de la tapa montada.
6. Conecte cables desde las terminales de tweeter del crossover hasta el propio tweeter con conectores faston. Conecte el cable rojo de la terminal (+) de la salida de tweeter del crossover al cable rojo (+) del tweeter.
7. Monte el tweeter haciéndolo encajar a presión en la copa de montaje.

## FRANÇAIS

**Figure 14**

#### MONTAGE DU TWEETER—ENCASTRÉ

1. Assurez un dégagement adéquat—le kit de montage encastré a une profondeur de 7/8" (22,2 mm).
2. Marquez le centre de l'endroit d'installation choisi et faites un trou de 2 po (50,8 mm) de diamètre à l'aide d'une scie-cloche, d'un foret ou d'un couteau tout usage.
3. Assemblez la coupelle, le crampon et la vis tel qu'indiqué—sans trop serrer.
4. Passez les fils à travers le trou rond à la base de la coupelle.

5. Insérez l'ensemble dans le trou de 2 po jusqu'à ce que la bordure du crampon pénètre sous la surface de montage puis resserrez la vis. Les pattes du crampon peuvent être repliées vers l'extérieur en insérant un tournevis dans les trous de la coupelle déjà en place.
6. Connectez les fils des bornes «tweeter» du séparateur aux fils des tweeters à l'aide des connecteurs rapides. Assurez-vous de connecter le fil rouge fil (+) du tweeter à la borne (+) de la sortie «tweeter» du séparateur.
7. Montez le tweeter en l'enclenchant dans la coupelle.

## DEUTSCH

---

### Abbildung 14

#### Bündige Montage

##### HOCHTÖNER-MONTAGE

1. Prüfen Sie, ob genug Freiraum da ist: Der Kit zur bündigen Montage ist 22,2 mm tief.
2. Markieren Sie den Mittelpunkt und schneiden Sie mit einer Lochsäge, einem Bohrer oder einem Teppichmesser ein Loch mit 50,8 mm Durchmesser.
3. Kombinieren Sie den Becher, die Klammer und die Flachkopfschraube lose, wie in der Abbildung gezeigt.
4. Führen Sie die Kabel durch die runde Öffnung unten am Becher.
5. Drücken Sie die Baugruppe in das Loch mit

50,8 mm Durchmesser, bis die Kante der Klammer sich unter der Montageebene befindet, und drehen Sie dann die Schraube fest. Die Arme der Klammer können nach außen gebogen werden, indem Sie einen Schraubendreher durch die Löcher im Becher einführen, während dieser noch montiert ist.

6. Verbinden Sie die Drähte von den Hochtöneranschlüssen am Crossover mit dem Hochtöner selbst unter Verwendung der Faston-Anschlüsse. Verbinden Sie den roten Draht vom (+) Anschluss des Crossover-Hochtönerausgangs mit dem roten (+) Draht am Hochtöner.
7. Befestigen Sie den Hochtöner, indem Sie ihn in den Montagebecher einrasten lassen.

## PORTUGUÊS

---

### Figura 14

#### Instalação alinhada com a superfície

##### INSTALAÇÃO DO TWEETER

1. Verifique se há espaço adequado: O kit de montagem embutida tem 22,2 mm (7/8 pol.) de profundidade.
2. Marque o centro do local de instalação e corte um orifício com diâmetro de 50,8 mm (2 pol.) usando uma serra copo, uma broca ou um estilete.
3. Monte a base, a presilha e os parafusos sem apertar, como ilustrado.
4. Passe os cabos através da abertura redonda situada na parte inferior da base.

5. Pressione o conjunto no orifício de 50,8 mm (2 pol.) de diâmetro até que a borda da presilha esteja abaixo da superfície de montagem e, em seguida, aperte o parafuso. Para dobrar as extremidades da presilha para fora, basta inserir uma chave de fenda através dos orifícios na base.

6. Conecte os cabos dos terminais do tweeter do crossover ao próprio tweeter usando os conectores faston. Conecte o cabo vermelho do terminal (+) da saída do tweeter do crossover no cabo vermelho (+) do tweeter.
7. Monte o tweeter encaixando-o na base de montagem.

## ITALIANO

---

### Figura 14

#### Fissaggio a filo

##### FISSAGGIO DEL TWEETER

1. Verificare che si possa assicurare lo spazio giusto: il kit di fissaggio a filo ha una profondità (d) di 22,2 mm.
2. Contrassegnare il centro del punto di installazione e praticare un foro di diametro pari a 50,8 mm (2") mediante una sega a tazza, una punta di trapano o un rasoio.
3. Montare la cassa, la piastra di fissaggio e la vite autofilettante senza serrare il complessivo, come illustrato.
4. Infilare i cavi nell'apertura circolare sulla parte inferiore della cassa.

5. Inserire il gruppo nel foro praticato finché il bordo della piastra di fissaggio non è sotto la superficie di fissaggio e poi serrare la vite. È possibile piegare verso l'esterno le alette della piastra di fissaggio inserendo un cacciavite nei fori della cassa dopo averla collocata.

6. Collegare i cavi dai terminali del crossover per il tweeter a quest'ultimo mediante i connettori Faston, collegando il cavo rosso dal terminale (+) dell'apposita uscita del crossover al cavo rosso (+) del tweeter.
7. Inserire il tweeter nella cassa accertandosi che si blocchi con uno scatto.

## ENGLISH

---

### DB6501 & DB5251

**Figure 15**  
**Surface Mount**  
TWEETER MOUNTING

1. Using the base of the surface mount cup as a template, mark the screw hole and drill them using a 1/8" (3mm) drill bit. Drill a second hole (for the speaker wire) using a 3/16" (5mm) drill bit.
2. Screw surface mount cup to the panel.
3. Push the tweeter wires through the open area at the bottom of the cup and through the 3/16" (5mm) hole in the panel.

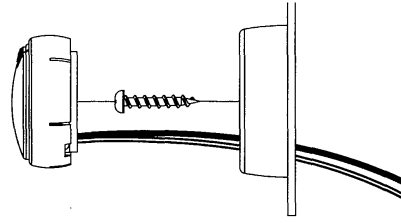

4. Connect wires from the tweeter terminals of the Crossover to the tweeter wires using faston connectors. Be sure to connect the red wire strand from the tweeter to the (+) terminal of the crossover tweeter output.
5. Mount the tweeter by snapping it into the mounting cup.

## ESPAÑOL

---

**Figura 15**  
**Montaje en superficie**  
MONTAJE DEL TWEETER

1. Usando la base de la copa de montaje en superficie como plantilla, marque el punto en que va a ir el agujero para el tornillo y haga el agujero con una broca perforadora de 3 mm (1/8 de plg). Haga un segundo agujero (para el cable del altavoz) con una broca perforadora de 5 mm (3/16 de plg).
2. Atornille la copa de montaje en superficie al panel interior.
3. Empuje los cables del tweeter a través del área abierta en la base de la copa y a través del agujero de 5 mm (3/16 de plg.) que hay en el panel.

4. Conecte cables desde las terminales de tweeter del crossover hasta los cables del tweeter con conectores faston. Asegúrese de conectar el cable rojo del tweeter a la terminal (+) de la salida de tweeter del crossover.
5. Monte el tweeter haciéndolo encajar a presión en la copa de montaje.

## FRANÇAIS

---

**Figure 15**  
MONTAGE DU TWEETER—EN SURFACE

1. Utilisant la base de la coupelle comme gabarit, marquez les trous de vis puis percez le panneau à l'aide d'une mèche de 1/8" (3 mm). Percez un deuxième trou (pour le fil de haut-parleur) utilisant une mèche de 3/16" (5 mm).
2. Vissez la coupelle à la surface du panneau.
3. Passez le fils du tweeter à travers le trou à la base de la coupelle et à travers le trou de 3/16" (5 mm) déjà percé dans le panneau.

4. Conecte cables desde las terminales de tweeter del crossover hasta los cables del tweeter con conectores faston. Asegúrese de conectar el cable rojo del tweeter a la terminal (+) de la salida de tweeter del crossover.
5. Monte el tweeter haciéndolo encajar a presión en la copa de montaje.

## DEUTSCH

---

### Abbildung 15

#### Oberflächenmontage

##### HOCHTÖNER-MONTAGE

1. Verwenden Sie die Unterseite des Oberflächenmontagebechers als Schablone und markieren Sie damit das Schraubenloch, das Sie mit einem 3-mm-Bohrer bohren. Bohren Sie ein zweites Loch (für das Lautsprecherkabel) mit einem 5-mm-Bohrer.
2. Schrauben Sie den Oberflächenmontagebecher an die Platte.
3. Schieben Sie die Hochtönerdrähte durch die Öffnung an der Unterseite des Bechers und das 5-mm-Loch in der Platte.
4. Verbinden Sie die Drähte von den Hochtöneranschlüssen am Crossover mit den Hochtönerdrähten unter Verwendung der Faston-Anschlüsse. Stellen Sie sicher, dass die rote Leitungsfaser vom Hochtöner an den (+) Anschluss des Crossover-Hochtöner-Ausgangs angeschlossen wird.
5. Befestigen Sie den Hochtöner, indem Sie ihn in den Montagebecher einrasten lassen.

## PORTUGUÊS

---

### Figura 15

#### Instalação na superfície

##### INSTALAÇÃO DO TWEETER

1. Use a base de montagem como um modelo para marcar o orifício do parafuso e perfure-o usando uma broca de 3 mm (1/8 pol.). Perfure um segundo orifício (para o cabo da caixa acústica) usando uma broca de 5 mm (3/16 pol.).
2. Afixe com os parafusos a base de montagem em superfície ao painel.
3. Passe os cabos do tweeter através da área aberta no fundo da base e através do orifício de 5 mm (3/16 pol.) no painel.
4. Conecte os cabos dos terminais do tweeter do crossover aos cabos do tweeter usando os conectores faston. Conecte a extremidade do cabo vermelho do tweeter ao terminal (+) da saída do tweeter do crossover.
5. Monte o tweeter encaixando-o na base de montagem.

## ITALIANO

---

### Figura 15

#### Fissaggio superficiale

##### FISSAGGIO DEL TWEETER

1. Utilizzando la base della cassa come dima, contrassegnare la posizione del foro per la vite e praticare il foro con una punta da trapano di 3 mm (1/8"), quindi praticare un secondo foro (per il cavo del diffusore) con una punta da trapano di 5 mm (3/16").
2. Avvitare la cassa sul pannello.
3. Infilare i cavi del tweeter nell'apertura sul fondo della cassa e nel foro da 5 mm praticato nel pannello.
4. Collegare i cavi dai terminali del crossover per il tweeter ai cavi di quest'ultimo mediante connettori Faston, collegando il cavo rosso dal tweeter all'apposito terminale (+) del crossover.
5. Inserire il tweeter nella cassa accertandosi che si blocchi con uno scatto.

## ENGLISH

### db Series Full Range/Component Systems Specifications

	<b>db351</b>	<b>db401</b>	<b>db461</b>	<b>db461p</b>	<b>db501</b>	<b>db521</b>
Type	3 1/2" coaxial	4" coaxial	4" x 6" coaxial	4" x 6" plate	5" coaxial	5 1/4" coaxial
Driver complement	3 1/2" (8.89cm) mid/woofer	4" (10.2cm) mid/woofer	4" x 6" (10cm x 15cm) mid/woofer	4" (10.2cm) mid/woofer	5" (12.7cm) mid/woofer	5 1/4" (13.0cm) mid/woofer
Tweeter complement	1/2" (12mm) soft dome tweeter	3/4" (19mm) soft dome tweeter	3/4" (19mm) soft dome tweeter	3/4" (19mm) soft dome tweeter	3/4" (19mm) soft dome tweeter	3/4" (19mm) soft dome tweeter
Mounting dimensions	3 1/8" (79.36mm)	4" (101.6mm)	6" x 4" (152.4mm x 101.6mm)	6" x 4" (152.4mm x 101.6mm)	4" (101.6mm)	4 11/16" (119mm)
Mounting depth (top)	1 1/2" (38.1mm)	1 13/16" (46.0mm)	1 15/16" (49.2mm)	1 13/16" (46.04mm)	1 13/16" (46.0mm)	2 5/16" (58.7mm)
Mounting depth (bottom)	1 11/16" (42.86mm)	1 15/16" (49.21mm)	2" (50.8mm)	2" (50.8mm)	1 15/16" (49.21mm)	2 7/16" (61.9mm)
Peak Power handling	105w	135w	120w	150w	135w	135w
Continuous Power handling	35w	45w	40w	50w	45w	45w
Nominal Impedance	4 Ω	4 Ω	4 Ω	4 Ω	4 Ω	4 Ω
Frequency response	90-22kHz	85-22kHz	75-22kHz	71-22kHz	65-22kHz	60-22kHz
Grille height	n/a	3/4" (6.35mm)	n/a	n/a	n/a	1" (25.4mm)
Sensitivity	91dB	91dB	91dB	91dB	93dB	93dB

## db Series Full Range/Component Systems Specifications

<b>db571</b>	<b>db651</b>	<b>db651s</b>	<b>db691</b>	<b>db5251</b>	<b>db6501</b>	<b>db1001</b>
5" x 7" coaxial	6 1/2" coaxial	6 1/2" slim mount coaxial	6" x 9" three way	5 1/4" component system	6 1/2" component system	1" tweeter
5" x 7" (12.7cm x 17.8cm) mid/woofer	6 1/2" (16.0cm) mid/woofer	6 1/2" (16.0cm) mid/woofer	6" x 9" (15cm x 22.9cm) mid/woofer	5 1/4" (13.0cm) mid/woofer	6 1/2" (16.0cm) mid/woofer	n/a mid/woofer
3/4" (19mm) soft dome tweeter	3/4" (19mm) soft dome tweeter	3/4" (19mm) soft dome tweeter	1" (25.4mm) soft dome tweeter 3/4" (19mm) soft dome tweeter	1" (25.4mm) soft dome tweeter	1" (25.4mm) soft dome tweeter	1" (25.4mm) soft dome tweeter
7 1/8" x 4 15/16" (181mm x 125.4mm)	5" (127mm)	5" (127mm)	8 1/2" x 5 3/4" (215.9mm x 146mm)	4 11/16" (119mm)	5" (127mm)	2 1/16" (52.39mm) mounting cup
2 3/16" (55.6mm)	2" (50.8mm)	2" (50.8mm)	3 3/16" (81.0mm)	2 5/16" (58.7mm)	2" (50.8mm)	1 3/16" (30.2mm)
2 5/8" (66.7mm)	2 5/16" (58.74mm)	2 5/16" (58.7mm)	3 3/4" (95.2mm)	2 7/16" (61.9mm)	2 5/16" (58.7mm)	1 1/32" (26.2mm)
180w	180w	165w	300w	250w	300w	180w
60w	60w	55w	100w	100w	100w	60w
4 Ω	4 Ω	4 Ω	4 Ω	4 Ω	4 Ω	4 Ω
52-22kHz	35-22kHz	50-22kHz	35-22kHz	53-23kHz	35-23kHz	23-4kHz
n/a	1 1/8" (28.58mm)	1 1/8" (28.58mm)	1 1/4" (31.75mm)	1" (25.4mm)	1 1/8" (28.58mm)	n/a
93dB	92dB	92dB	93dB	93dB	92dB	92dB

**Especificaciones de los modelos de la serie de gama completa de frecuencias**

	<b>db351</b>	<b>db401</b>	<b>db461</b>	<b>db461p</b>	<b>db501</b>	<b>db521</b>
Tipo	3 1/2" coaxial	4" coaxial	4" x 6" coaxial	4" x 6" placa	5" coaxial	5 1/4" coaxial
Dotación de excitadores	3 1/2" (8.89cm) woofer y frecuencias medias	4" (10.2cm) woofer y frecuencias medias	4" x 6" (10cm x 15cm) woofer y frecuencias medias	4" (10.2cm) woofer y frecuencias medias	5" (12.7cm) woofer y frecuencias medias	5 1/4" (13.0cm) woofer y frecuencias medias
Dotación de tweeters	1/2" (12mm) tweeter de domo blando	3/4" (19mm) tweeter de domo blando	3/4" (19mm) tweeter de domo blando	3/4" (19mm) tweeter de domo blando	3/4" (19mm) tweeter de domo blando	3/4" (19mm) tweeter de domo blando
Dimensiones de montaje	3 1/8" (79.36mm)	4" (101.6mm)	6" x 4" (152.4mm x 101.6mm)	6" x 4" (152.4mm x 101.6mm)	4" (101.6mm)	4 11/16" (119mm)
Profundidad de montaje (arriba)	1 1/2" (38.1mm)	1 13/16" (46.0mm)	1 15/16" (49.2mm)	1 13/16" (46.04mm)	1 13/16" (46.0mm)	2 5/16" (58.7mm)
Profundidad de montaje (abajo)	1 11/16" (42.86mm)	1 15/16" (49.21mm)	2" (50.8mm)	2" (50.8mm)	1 15/16" (49.21mm)	2 7/16" (61.9mm)
Administración de potencia máxima	105w	135w	120w	150w	135w	135w
Administración de potencia continua	35w	45w	40w	50w	45w	45w
Impedancia nominal	4 Ω	4 Ω	4 Ω	4 Ω	4 Ω	4 Ω
Respuesta de frecuencias	90-22kHz	85-22kHz	75-22kHz	71-22kHz	65-22kHz	60-22kHz
Altura de la rejilla	n/a	3/4" (6.35mm)	n/a	n/a	n/a	1" (25.4mm)
Sensibilidad	91dB	91dB	91dB	91dB	93dB	93dB



## Especificaciones de sistemas de componentes de los modelos de la serie db

<b>db571</b>	<b>db651</b>	<b>db651s</b>	<b>db691</b>	<b>db5251</b>	<b>db6501</b>	<b>db1001</b>
5" x 7"	6 1/2" coaxial	6 1/2" coaxial de montaje delgado	6" x 9" tres canales	5 1/4" sistema de componentes	6 1/2" sistema de componentes	1" tweeter
5" x 7" (12.7cm x 17.8cm) woofer y frecuencias medias	6 1/2" (16.0cm) woofer y frecuencias medias	6 1/2" (16.0cm) woofer y frecuencias medias	6" x 9" (15cm x 22.9cm) woofer y frecuencias medias	5 1/4" (13.0cm) woofer y frecuencias medias	6 1/2" (16.0cm) woofer y frecuencias medias	n/a woofer y frecuencias medias
3/4" (19mm) tweeter de domo blando	3/4" (19mm) tweeter de domo blando	3/4" (19mm) tweeter de domo blando	1" (25.4mm) tweeter de domo blando 3/4" (19mm) tweeter de domo blando	1" (25.4mm) tweeter de domo blando	1" (25.4mm) tweeter de domo blando	1" (25.4mm) tweeter de domo blando
7 1/8" x 4 15/16" (181mm x 125.4mm)	5" (127mm)	5" (127mm)	8 1/2" x 5 3/4" (215.9mm x 146mm)	4 11/16" (119mm)	5" (127mm)	2 1/16" (52.39mm) copa de montaje
2 3/16" (55.6mm)	2" (50.8mm)	2" (50.8mm)	3 3/16" (81.0mm)	2 5/16" (58.7mm)	2" (50.8mm)	1 3/16" (30.2mm)
2 5/8" (66.7mm)	2 5/16" (58.74mm)	2 5/16" (58.7mm)	3 3/4" (95.2mm)	2 7/16" (61.9mm)	2 5/16" (58.7mm)	1 1/32" (26.2mm)
180w	180w	165w	300w	250w	300w	180w
60w	60w	55w	100w	100w	100w	60w
4 Ω	4 Ω	4 Ω	4 Ω	4 Ω	4 Ω	4 Ω
52-22kHz	35-22kHz	50-22kHz	35-22kHz	53-23kHz	35-23kHz	23-4kHz
n/a	1 1/8" (28.58mm)	1 1/8" (28.58mm)	1 1/4" (31.75mm)	1" (25.4mm)	1 1/8" (28.58mm)	n/a
93dB	92dB	92dB	93dB	93dB	92dB	92dB

**Série db à gamme intégrale—Fiche technique**

	<b>db351</b>	<b>db401</b>	<b>db461</b>	<b>db461p</b>	<b>db501</b>	<b>db521</b>
Type	3 1/2" coaxial	4" coaxial	4" x 6" coaxial	4" x 6" plateau	5" coaxial	5 1/4" coaxial
Transducteurs	3 1/2" (8.89cm) méd/woofer	4" (10.2cm) méd/woofer	4" x 6" (10cm x 15cm) méd/woofer	4" (10.2cm) méd/woofer	5" (12.7cm) méd/woofer	5 1/4" (13.0cm) méd/woofer
Tweeter complément	1/2" (12mm) tweeter à dôme souple	3/4" (19mm) tweeter à dôme souple	3/4" (19mm) tweeter à dôme souple	3/4" (19mm) tweeter à dôme souple	3/4" (19mm) tweeter à dôme souple	3/4" (19mm) tweeter à dôme souple
Dimensions de montage	3 1/8" (79.36mm)	4" (101.6mm)	6" x 4" (152.4mm x 101.6mm)	6" x 4" (152.4mm x 101.6mm)	4" (101.6mm)	4 11/16" (119mm)
Profondeur de montage (dessus)	1 1/2" (38.1mm)	1 13/16" (46.0mm)	1 15/16" (49.2mm)	1 13/16" (46.04mm)	1 13/16" (46.0mm)	2 5/16" (58.7mm)
Profondeur de montage (dessous)	1 11/16" (42.86mm)	1 15/16" (49.21mm)	2" (50.8mm)	2" (50.8mm)	1 15/16" (49.21mm)	2 7/16" (61.9mm)
Capacité de puissance (crête)	105w	135w	120w	150w	135w	135w
Capacité de puissance (continue)	35w	45w	40w	50w	45w	45w
Impédance nominale	4 Ω	4 Ω	4 Ω	4 Ω	4 Ω	4 Ω
Réponse en fréquences	90-22kHz	85-22kHz	75-22kHz	71-22kHz	65-22kHz	60-22kHz
Hauteur de la grille	n/a	3/4" (6.35mm)	n/a	n/a	n/a	1" (25.4mm)
Sensibilité	91dB	91dB	91dB	91dB	93dB	93dB

## Systèmes-composants de la Série db—Fiche technique

<b>db571</b>	<b>db651</b>	<b>db651s</b>	<b>db691</b>	<b>db5251</b>	<b>db6501</b>	<b>db1001</b>
5" x 7" coaxial	6 1/2" coaxial	6 1/2" coaxial à profil ultra-mince	6" x 9" 3 voies	5 1/4" système- composants	6 1/2" système- composants	1" tweeter
5" x 7" (12.7cm x 17.8cm) méd/woofer	6 1/2" (16.0cm) méd/woofer	6 1/2" (16.0cm) méd/woofer	6" x 9" (15cm x 22.9cm) méd/woofer	5 1/4" (13.0cm) méd/woofer	6 1/2" (16.0cm) méd/woofer	n/a méd/woofer
3/4" (19mm) tweeter à dôme souple	3/4" (19mm) tweeter à dôme souple	3/4" (19mm) tweeter à dôme souple	1" (25.4mm) tweeter à dôme souple 3/4" (19mm) tweeter à dôme souple	1" (25.4mm) tweeter à dôme souple	1" (25.4mm) tweeter à dôme souple	1" (25.4mm) tweeter à dôme souple
7 1/8" x 4 15/16" (181mm x 125.4mm)	5" (127mm)	5" (127mm)	8 1/2" x 5 3/4" (215.9mm x 146mm)	4 11/16" (119mm)	5" (127mm)	2 1/16" (52.39mm) coupelle de montage
2 3/16" (55.6mm)	2" (50.8mm)	2" (50.8mm)	3 3/16" (81.0mm)	2 5/16" (58.7mm)	2" (50.8mm)	1 3/16" (30.2mm)
2 5/8" (66.7mm)	2 5/16" (58.74mm)	2 5/16" (58.7mm)	3 3/4" (95.2mm)	2 7/16" (61.9mm)	2 5/16" (58.7mm)	1 1/32" (26.2mm)
180w	180w	165w	300w	250w	300w	180w
60w	60w	55w	100w	100w	100w	60w
4 Ω	4 Ω	4 Ω	4 Ω	4 Ω	4 Ω	4 Ω
52-22kHz	35-22kHz	50-22kHz	35-22kHz	53-23kHz	35-23kHz	23-4kHz
n/a	1 1/8" (28.58mm)	1 1/8" (28.58mm)	1 1/4" (31.75mm)	1" (25.4mm)	1 1/8" (28.58mm)	n/a
93dB	92dB	92dB	93dB	93dB	92dB	92dB

## DEUTSCH

### db-Serie: Vollbereichs-Spezifikationen

	<b>db351</b>	<b>db401</b>	<b>db461</b>	<b>db461p</b>	<b>db501</b>	<b>db521</b>
Typ	3 1/2" koaxial	4" koaxial	4" x 6" koaxial	4" x 6" platte	5" koaxial	5 1/4" koaxial
Treiberbaugruppe	3 1/2" (8.89cm) mitteltieftöner	4" (10.2cm) mitteltieftöner	4" x 6" (10cm x 15cm) mitteltieftöner	4" (10.2cm) mitteltieftöner	5" (12.7cm) mitteltieftöner	5 1/4" (13.0cm) mitteltieftöner
Hochtöner- baugruppe	1/2" (12mm) weichkalotten- hochtöner	3/4" (19mm) weichkalotten- hochtöner	3/4" (19mm) weichkalotten- hochtöner	3/4" (19mm) weichkalotten- hochtöner	3/4" (19mm) weichkalotten- hochtöner	3/4" (19mm) weichkalotten- hochtöner
Montageab- messungen	3 1/8" (79.36mm)	4" (101.6mm)	6" x 4" (152.4mm x 101.6mm)	6" x 4" (152.4mm x 101.6mm)	4" (101.6mm)	4 11/16" (119mm)
Befestigung- stiefe (oben)	1 1/2" (38.1mm)	1 13/16" (46.0mm)	1 15/16" (49.2mm)	1 13/16" (46.04mm)	1 13/16" (46.0mm)	2 5/16" (58.7mm)
Befestigung- stiefe (unten)	1 11/16" (42.86mm)	1 15/16" (49.21mm)	2" (50.8mm)	2" (50.8mm)	1 15/16" (49.21mm)	2 7/16" (61.9mm)
Spitzenbelast- barkeit	105w	135w	120w	150w	135w	135w
Dauerbelast- barkeit	35w	45w	40w	50w	45w	45w
Nennimpedanz	4 Ω	4 Ω	4 Ω	4 Ω	4 Ω	4 Ω
Frequenzgang	90-22kHz	85-22kHz	75-22kHz	71-22kHz	65-22kHz	60-22kHz
Grillhöhe	n/a	3/4" (6.35mm)	n/a	n/a	n/a	1" (25.4mm)
Empfindlichkeit	91dB	91dB	91dB	91dB	93dB	93dB

## db-Serie: Komponentensystem-Spezifikationen

<b>db571</b>	<b>db651</b>	<b>db651s</b>	<b>db691</b>	<b>db5251</b>	<b>db6501</b>	<b>db1001</b>
5" x 7" koaxial	6 1/2" koaxial	6 1/2" platzsparende koaxialmontage	6" x 9" dreiweg	5 1/4" komponenten- system	6 1/2" komponenten- system	1" tweeter
5" x 7" (12.7cm x 17.8cm) mitteltieftöner	6 1/2" (16.0cm) mitteltieftöner	6 1/2" (16.0cm) mitteltieftöner	6" x 9" (15cm x 22.9cm) mitteltieftöner	5 1/4" (13.0cm) mitteltieftöner	6 1/2" (16.0cm) mitteltieftöner	n/a mitteltieftöner
3/4" (19mm) weichkalotten- hochtöner	3/4" (19mm) weichkalotten- hochtöner	3/4" (19mm) weichkalotten- hochtöner	1" (25.4mm) weichkalotten- hochtöner 3/4" (19mm) weichkalotten- hochtöner	1" (25.4mm) weichkalotten- hochtöner	1" (25.4mm) weichkalotten- hochtöner	1" (25.4mm) weichkalotten- hochtöner
7 1/8" x 4 15/16" (181mm x 125.4mm)	5" (127mm)	5" (127mm)	8 1/2" x 5 3/4" (215.9mm x 146mm)	4 11/16" (119mm)	5" (127mm)	2 1/16" (52.39mm) montage- becher
2 3/16" (55.6mm)	2" (50.8mm)	2" (50.8mm)	3 3/16" (81.0mm)	2 5/16" (58.7mm)	2" (50.8mm)	1 3/16" (30.2mm)
2 5/8" (66.7mm)	2 5/16" (58.74mm)	2 5/16" (58.7mm)	3 3/4" (95.2mm)	2 7/16" (61.9mm)	2 5/16" (58.7mm)	1 1/32" (26.2mm)
180w	180w	165w	300w	250w	300w	180w
60w	60w	55w	100w	100w	100w	60w
4 Ω	4 Ω	4 Ω	4 Ω	4 Ω	4 Ω	4 Ω
52-22kHz	35-22kHz	50-22kHz	35-22kHz	53-23kHz	35-23kHz	23-4kHz
n/a	1 1/8" (28.58mm)	1 1/8" (28.58mm)	1 1/4" (31.75mm)	1" (25.4mm)	1 1/8" (28.58mm)	n/a
93dB	92dB	92dB	93dB	93dB	92dB	92dB

## PORTUGUÊS

### Especificações da série db

	<b>db351</b>	<b>db401</b>	<b>db461</b>	<b>db461p</b>	<b>db501</b>	<b>db521</b>
Tipo	3 1/2" coaxial	4" coaxial	4" x 6" coaxial	4" x 6" placa	5" coaxial	5 1/4" coaxial
Driver complement	3 1/2" (8.89cm) woofer médio	4" (10.2cm) woofer médio	4" x 6" (10cm x 15cm) woofer médio	4" (10.2cm) woofer médio	5" (12.7cm) woofer médio	5 1/4" (13.0cm) woofer médio
Tweeter complement	1/2" (12mm) tweeter de cúpula macia	3/4" (19mm) tweeter de cúpula macia	3/4" (19mm) tweeter de cúpula macia	3/4" (19mm) tweeter de cúpula macia	3/4" (19mm) tweeter de cúpula macia	3/4" (19mm) tweeter de cúpula macia
Dimensões para instalação	3 1/8" (79.36mm)	4" (101.6mm)	6" x 4" (152.4mm x 101.6mm)	6" x 4" (152.4mm x 101.6mm)	4" (101.6mm)	4 11/16" (119mm)
Profundidade de instalação (superior)	1 1/2" (38.1mm)	1 13/16" (46.0mm)	1 15/16" (49.2mm)	1 13/16" (46.04mm)	1 13/16" (46.0mm)	2 5/16" (58.7mm)
Profundidade de instalação (inferior)	1 11/16" (42.86mm)	1 15/16" (49.21mm)	2" (50.8mm)	2" (50.8mm)	1 15/16" (49.21mm)	2 7/16" (61.9mm)
Capacidade de processamento de pico de potência	105w	135w	120w	150w	135w	135w
Capacidade de processamento contínuo	35w	45w	40w	50w	45w	45w
Impedância nominal	4 Ω	4 Ω	4 Ω	4 Ω	4 Ω	4 Ω
Resposta de freq.	90-22kHz	85-22kHz	75-22kHz	71-22kHz	65-22kHz	60-22kHz
Altura da grade	n/a	3/4" (6.35mm)	n/a	n/a	n/a	1" (25.4mm)
Sensibilidade	91dB	91dB	91dB	91dB	93dB	93dB

## Especificações dos sistemas componentes da série db

<b>db571</b>	<b>db651</b>	<b>db651s</b>	<b>db691</b>	<b>db5251</b>	<b>db6501</b>	<b>db1001</b>
5" x 7" coaxial	6 1/2" coaxial	6 1/2" coaxial de perfil delgado	6" x 9" tridirecional	5 1/4" sistema componente	6 1/2" sistema componente	1" tweeter
5" x 7" (12.7cm x 17.8cm) woofer médio	6 1/2" (16.0cm) woofer médio	6 1/2" (16.0cm) woofer médio	6" x 9" (15cm x 22.9cm) woofer médio	5 1/4" (13.0cm) woofer médio	6 1/2" (16.0cm) woofer médio	n/a woofer médio
3/4" (19mm) tweeter de cúpula macia	3/4" (19mm) tweeter de cúpula macia	3/4" (19mm) tweeter de cúpula macia	1" (25.4mm) tweeter de cúpula macia 3/4" (19mm) tweeter de cúpula macia	1" (25.4mm) tweeter de cúpula macia	1" (25.4mm) tweeter de cúpula macia	1" (25.4mm) tweeter de cúpula macia
7 1/8" x 4 15/16" (181mm x 125.4mm)	5" (127mm)	5" (127mm)	8 1/2" x 5 3/4" (215.9mm x 146mm)	4 11/16" (119mm)	5" (127mm)	2 1/16" (52.39mm) base de montagem
2 3/16" (55.6mm)	2" (50.8mm)	2" (50.8mm)	3 3/16" (81.0mm)	2 5/16" (58.7mm)	2" (50.8mm)	1 3/16" (30.2mm)
2 5/8" (66.7mm)	2 5/16" (58.74mm)	2 5/16" (58.7mm)	3 3/4" (95.2mm)	2 7/16" (61.9mm)	2 5/16" (58.7mm)	1 1/32" (26.2mm)
180w	180w	165w	300w	250w	300w	180w
60w	60w	55w	100w	100w	100w	60w
4 Ω	4 Ω	4 Ω	4 Ω	4 Ω	4 Ω	4 Ω
52-22kHz	35-22kHz	50-22kHz	35-22kHz	53-23kHz	35-23kHz	23-4kHz
n/a	1 1/8" (28.58mm)	1 1/8" (28.58mm)	1 1/4" (31.75mm)	1" (25.4mm)	1 1/8" (28.58mm)	n/a
93dB	92dB	92dB	93dB	93dB	92dB	92dB

**Dati tecnici dei modelli Serie db**

	<b>db351</b>	<b>db401</b>	<b>db461</b>	<b>db461p</b>	<b>db501</b>	<b>db521</b>
Tipo	3 1/2" coassiale	4" coassiale	4" x 6" coassiale	4" x 6" piastra	5" coassiale	5 1/4" coassiale
Driver complement	3 1/2" (8.89cm) mid/woofer	4" (10.2cm) mid/woofer	4" x 6" (10cm x 15cm) mid/woofer	4" (10.2cm) mid/woofer	5" (12.7cm) mid/woofer	5 1/4" (13.0cm) mid/woofer
Tweeter complement	1/2" (12mm) tweeter a cupola morbida	3/4" (19mm) tweeter a cupola morbida	3/4" (19mm) tweeter a cupola morbida	3/4" (19mm) tweeter a cupola morbida	3/4" (19mm) tweeter a cupola morbida	3/4" (19mm) tweeter a cupola morbida
Dimensioni di fissaggio	3 1/8" (79.36mm)	4" (101.6mm)	6" x 4" (152.4mm x 101.6mm)	6" x 4" (152.4mm x 101.6mm)	4" (101.6mm)	4 11/16" (119mm)
Profondità di fissaggio (parte superiore)	1 1/2" (38.1mm)	1 13/16" (46.0mm)	1 15/16" (49.2mm)	1 13/16" (46.04mm)	1 13/16" (46.0mm)	2 5/16" (58.7mm)
Profondità di fissaggio (parte inferiore)	1 11/16" (42.86mm)	1 15/16" (49.21mm)	2" (50.8mm)	2" (50.8mm)	1 15/16" (49.21mm)	2 7/16" (61.9mm)
Potenza di picco nominale	105w	135w	120w	150w	135w	135w
Potenza continua nominale	35w	45w	40w	50w	45w	45w
Impedenza nominale	4 Ω	4 Ω	4 Ω	4 Ω	4 Ω	4 Ω
Risposta in frequenza	90-22kHz	85-22kHz	75-22kHz	71-22kHz	65-22kHz	60-22kHz
Altezza griglia	n/a	3/4" (6.35mm)	n/a	n/a	n/a	1" (25.4mm)
Sensibilità	91dB	91dB	91dB	91dB	93dB	93dB



## Dati tecnici dei sistemi componenti Serie db

<b>db571</b>	<b>db651</b>	<b>db651s</b>	<b>db691</b>	<b>db5251</b>	<b>db6501</b>	<b>db1001</b>
5" x 7" coassiale	6 1/2" coassiale	6 1/2" coassiale a filo	6" x 9" a tre vie	5 1/4" sistema componente	6 1/2" sistema componente	1" tweeter
5" x 7" (12.7cm x 17.8cm) mid/woofer	6 1/2" (16.0cm) mid/woofer	6 1/2" (16.0cm) mid/woofer	6" x 9" (15cm x 22.9cm) mid/woofer	5 1/4" (13.0cm) mid/woofer	6 1/2" (16.0cm) mid/woofer	n/a mid/woofer
3/4" (19mm) tweeter a cupola morbida	3/4" (19mm) tweeter a cupola morbida	3/4" (19mm) tweeter a cupola morbida	1" (25.4mm) tweeter a cupola 3/4" (19mm) tweeter a cupola morbida	1" (25.4mm) tweeter a cupola morbida	1" (25.4mm) tweeter a cupola morbida	1" (25.4mm) tweeter a cupola morbida
7 1/8" x 4 15/16" (181mm x 125.4mm)	5" (127mm)	5" (127mm)	8 1/2" x 5 3/4" (215.9mm x 146mm)	4 11/16" (119mm)	5" (127mm)	2 1/16" (52.39mm) cassa
2 3/16" (55.6mm)	2" (50.8mm)	2" (50.8mm)	3 3/16" (81.0mm)	2 5/16" (58.7mm)	2" (50.8mm)	1 3/16" (30.2mm)
2 5/8" (66.7mm)	2 5/16" (58.74mm)	2 5/16" (58.7mm)	3 3/4" (95.2mm)	2 7/16" (61.9mm)	2 5/16" (58.7mm)	1 1/32" (26.2mm)
180w	180w	165w	300w	250w	300w	180w
60w	60w	55w	100w	100w	100w	60w
4 Ω	4 Ω	4 Ω	4 Ω	4 Ω	4 Ω	4 Ω
52-22kHz	35-22kHz	50-22kHz	35-22kHz	53-23kHz	35-23kHz	23-4kHz
n/a	1 1/8" (28.58mm)	1 1/8" (28.58mm)	1 1/4" (31.75mm)	1" (25.4mm)	1 1/8" (28.58mm)	n/a
93dB	92dB	92dB	93dB	93dB	92dB	92dB



## **1 YEAR WARRANTY**

Polk Audio, Inc. warrants to the original purchaser only that this Polk Audio db Product (the Product) will be free from defects in materials and workmanship for a period of (1) one year from the date of original retail purchase from a Polk Audio Authorized Dealer. However, this warranty will automatically terminate prior to the expiration of the (1) one year period if the original retail purchaser sells or otherwise transfers the Product to any other party. The original retail purchaser shall herein after be referred to as "you." To allow Polk Audio to offer the best possible warranty service, please fill out the Product Registration Card(s) and send them to the Factory at the address provided in the Registration Card within (10) ten days of the date of purchase.

Defective Products must be shipped, together with a proof of purchase, prepaid insured to the Authorized Polk Audio Dealer from whom you purchased the Product, or to 2550 Britannia Blvd., Suite A, San Diego, CA 92154. Products must be shipped in the original shipping container or its equivalent; in any case the risk of loss or damage in transit is to be borne by you. If, upon examination at the Factory or Polk Audio Authorized Dealer it is determined that the unit was defective in materials or workmanship at any time during the Warranty period, Polk Audio or the Polk Audio Dealer will, at its option, repair or replace this Product at no additional charge, except as set forth below. All replaced parts and Products become property of Polk Audio. Products replaced or repaired under this Warranty will be returned to you, within a reasonable time, freight prepaid.

This Warranty does not include service or parts to repair damage caused by accident, disaster, misuse, abuse, negligence, inadequate packing or shipping procedures, commercial use, voltage inputs in excess of the rated maximum of the unit, cosmetic appearance of the cabinetry not directly attributable to defects in materials or workmanship, or service, repair, or modifications of the Product which has not been authorized or approved by Polk Audio.

This Warranty is in lieu of all other expressed Warranties. If this Product is defective in materials and workmanship as warranted above, your sole remedy shall be repair or replacement as provided above. In no event will Polk Audio, Inc. be liable to you for any incidental or consequential damages arising out of the use or inability to use the Product, even if Polk Audio, Inc. or a Polk Audio Dealer has been advised of the possibility of such damages, or any other claim by any other party. Some states do not allow the exclusion or limitation of consequential damages, so the above limitation and exclusion may not apply to you. This Warranty gives you specific legal rights which may vary from state to state.

This warranty applies only to Products purchased in the United States of America, its possessions, and U.S. and NATO armed forces exchanges and audio clubs. The Warranty terms and conditions applicable to Products purchased in other countries are available from the Polk Audio Authorized Distributors in such countries.

polkaudio®

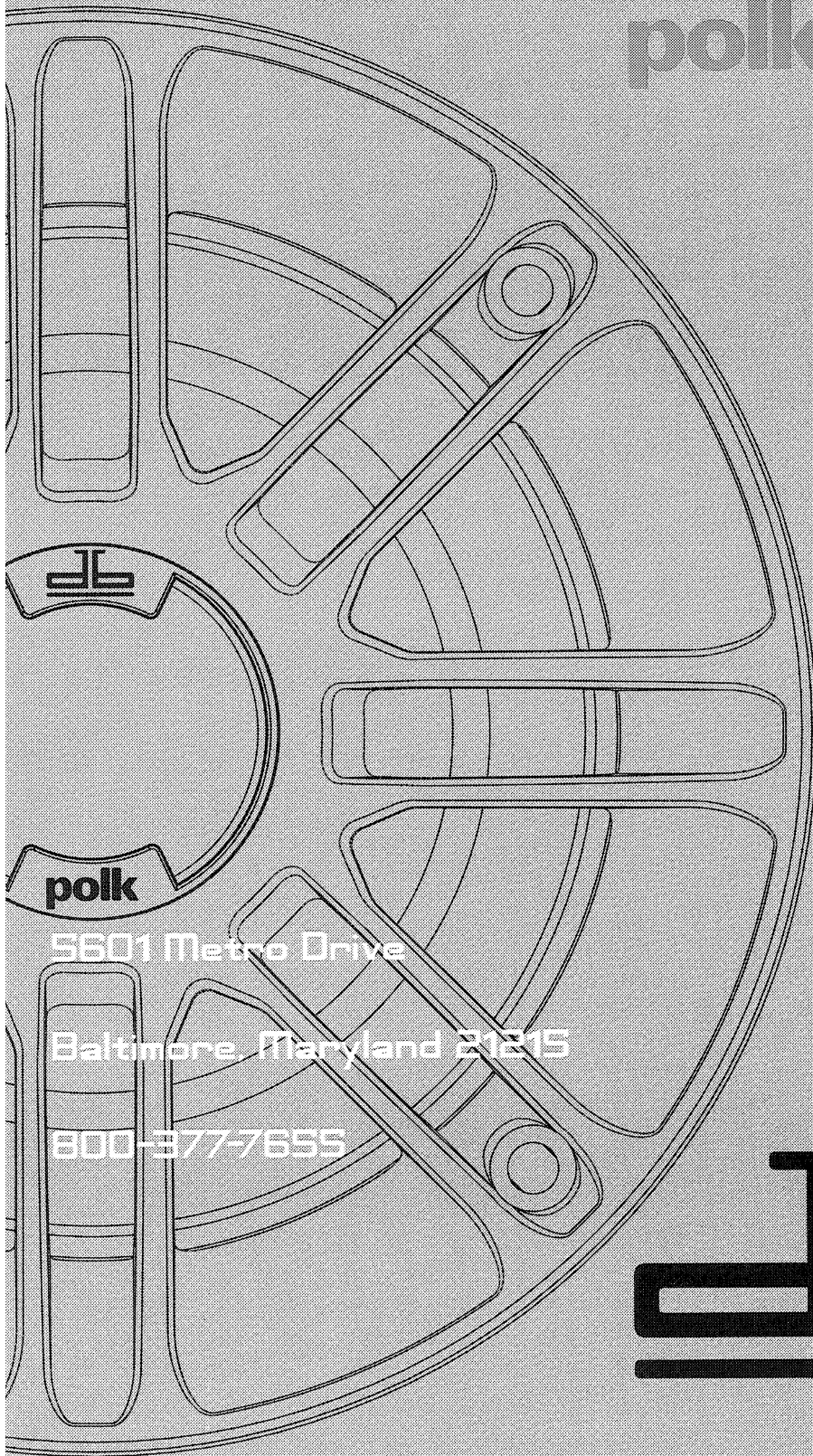

polk

5601 Metro Drive

Baltimore, Maryland 21215

800-377-7655

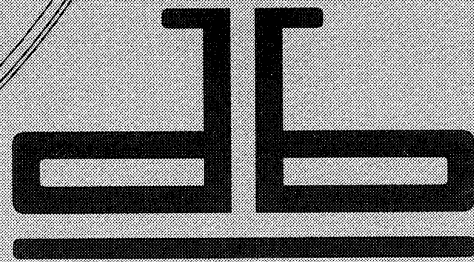

[www.polkaudio.com](http://www.polkaudio.com)



**polkaudio®**

This is your Product Model and Serial Number. Enter this number in the "Serial Number" space when registering your product online. Keep this card handy for Model and Serial Number reference when calling Polk Customer Service.

SERIAL #: 

# Register Your New Polk Audio Product Online NOW for a Chance to win \$500 of Polk Product

[www.polkaudio.com/registration/](http://www.polkaudio.com/registration/)

**Become a valued member of the Polk Family and get a chance to win FREE Speakers. Registering your new product:**

- ▶ Creates a permanent record of your purchase, in case you misplace your original receipt.
- ▶ Enters you in our monthly FREE drawing for \$500-worth of Polk Audio Speakers.
- ▶ Allows you to enroll in Club Polk: for informative Polk Website Forums, special discounts in the Polk Webstore, advance notice of Polk Promos, and discounts on Authorized Polk Audio parts.
- ▶ Keeps you up to date when there is news and announcements about your product.
- ▶ Gives you the option to "opt-in" for Polk Audio's Audio Enjoyment Enhancers: Our Monthly Emails, with news, reviews and tips on everything audio; and our FREE Polk Audio Newspaper.

**We take your privacy seriously. Polk Audio does not share or sell information to any other parties, unless directed by court order.**

Registering your product has no effect on your warranty. Warranties apply as stated in your product manual. Please be sure to keep your original purchase receipt.

No Internet access? Call Polk Audio Customer Service 800-377-7655 (US & Canada only). Outside the US & Canada, call 410-358-3600. We'll walk you through the simple registration process!